

## Application

VBS-9263 series single seat, stem up to close, two-way valves control water from 20 to 300°F (-7 to 149°C) or steam to 300°F (149°C) maximum in heating or air conditioning systems. They are used for two-position or proportional control applications. Valve assemblies require an actuator and a valve linkage that must be purchased separately.



---

**Danger:** Do not use for combustible gas applications. The VBS-9263 series valve packings are not rated for combustible gas applications, and if used in these applications, gas leaks and explosions could result.

---

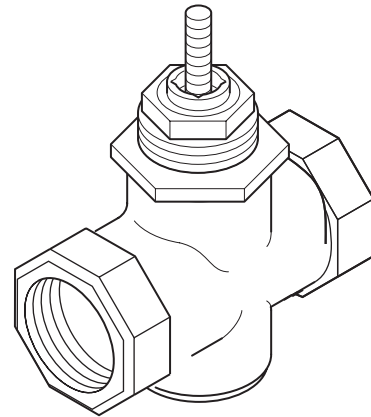

## Features

- Valve sizes 1/2" and 3/4"
- 250 psig pressure rating per ANSI Standards (B16.15–1985)
- Spring-loaded TFE packing
- American Standard Taper Pipe Thread (NPT) connections

## Applicable Literature

- TAC Valve Products Catalog, F-27384
- TAC Reference Manual, F-21683
- TAC Application Manual, F-21335
- Control Valve Sizing, F-13755
- EN-205 Water System Guidelines, F-26080

# SPECIFICATIONS

**Table-1 Specifications/Models.**

Specifications		Valve Body Series VBS-9263-0-6-P	
<b>Service</b>		Hot Water and Steam	
<b>Flow Characteristics (Figure-1)</b>		Modified Linear	
<b>Action</b>		Stem Up Closed	
<b>Sizes</b>		1/2" and 3/4"	
<b>Type of End Fitting</b>		NPT	
<b>Valve Materials</b>	<b>Body</b>	316 Stainless Steel	
	<b>Seat</b>	316 Stainless Steel	
	<b>Stem</b>	316 Stainless Steel	
	<b>Plug</b>	316 Stainless Steel	
	<b>Packing</b>	Spring-loaded TFE	
	<b>Disc</b>	EPDM	
<b>ANSI Pressure Class (Figure-2)</b>		250 (up to 400 psig below 150°F)	
<b>Maximum Inlet Pressure, Steam</b>		100 psig (690 kPa)	
<b>Allowable Control Media Temperature</b>		20 to 300°F (-7 to 149°C)	
<b>Allowable Differential Pressure for Water<sup>a</sup></b>		35 psi (241 kPa) Max. for Normal Life (refer to "Cavitation Limitations on Valve Pressure Drop" on page 7)	
<b>Allowable Differential Pressure for Steam<sup>a</sup></b>		35 psi (241 kPa)	
<b>Valve Size</b>	<b>C<sub>v</sub> Rating<sup>b</sup></b>	<b>k<sub>vs</sub> Rating<sup>b</sup></b>	<b>Complete Valve Body Part Number</b>
1/2"	0.10	0.09	<b>VBS-9263-0-6-31</b>
	0.22	0.19	<b>VBS-9263-0-6-33</b>
	0.4	0.3	<b>VBS-9263-0-6-01</b>
	0.75	0.65	<b>VBS-9263-0-6-35</b>
	0.95	0.82	<b>VBS-9263-0-6-36</b>
	1.3	1.1	<b>VBS-9263-0-6-02</b>
	1.75	1.51	<b>VBS-9263-0-6-37</b>
	2.2	1.9	<b>VBS-9263-0-6-03</b>
	2.80	2.42	<b>VBS-9263-0-6-38</b>
	3.25	2.81	<b>VBS-9263-0-6-39</b>
3/4"	3.6	3.1	<b>VBS-9263-0-6-04</b>
	4.3	3.7	<b>VBS-9263-0-6-45</b>
	5.0	4.3	<b>VBS-9263-0-6-05</b>
	6.2	5.4	<b>VBS-9263-0-6-06</b>

<sup>a</sup> Maximum recommended differential pressure in open position. Do not exceed recommended differential pressure (pressure drop) or integrity of parts may be affected. Exceeding maximum recommended differential pressure voids product warranty.

<sup>b</sup>  $k_{vs} = m^3/h$  ( $\Delta P = 100$  kPa)      $C_v = k_{vs} \times 1.156$

## Close-off Pressure Rating

The close-off pressure rating is dependent on the size of the valve, valve linkage, and actuator. Consult the **TAC Valve Products Catalog, F-27384**, for close-off ratings.

### Normal Position of Valve Assembly

For a valve assembly (valve, linkage, and actuator) to have a normal (spring return) position, the actuator must be of the spring return type. See Table-2 for normal position of valve assemblies.

**Table-2 Required Compatible Actuators/Linkages.**

Actuator Series	Required Valve Linkage	Normal Position
MA-5210, MA-5211, MA-5213	AV-600	Normally Closed
MF-5X1X	AV-600 & AV-601	
MK-2690	AV-400	
MP-5210, MP-5211, MP-5213	AV-600 & AV-601	
MP-5410, MP-5411, MP-5413		
MPR-5610, MPR-5611, MPR-5613		
MPR-5713		

### Flow Characteristics

All valves have modified equal percentage flow characteristics. That is, for equal increments of valve stem stroke, the change in flow rate with respect to valve stroke may be expressed as a constant percent of the flow rate at the time of the change. The change of flow rate with respect to valve stroke is relatively small when the valve plug is near the valve seat and relatively high when the valve plug is nearly wide open. See Figure-1 for typical modified equal percentage flow characteristics of VBS-9263 series valve bodies.

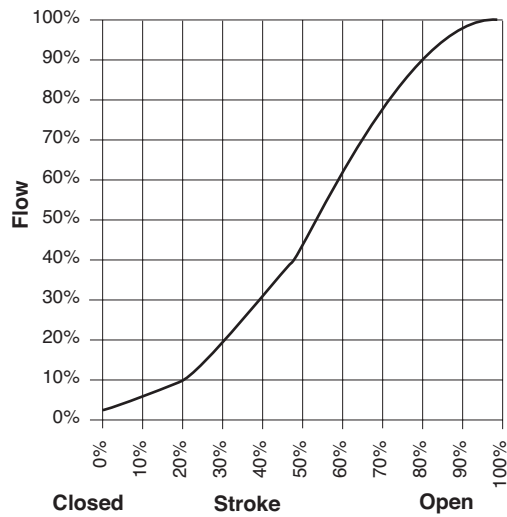

Figure-1 Typical Modified Equal Percentage Flow Characteristics.

## Rangeability

Rangeability is the ratio of rated flow to the minimum controllable flow through a valve. Table-3 lists the rangeability for VBS-9263 series valves.

**Table-3 Rangeability.**

Valve Body Part Number	Nominal Rangeability	Valve Body Part Number	Nominal Rangeability
VBS-9263-0-6-01	4	VBS-9263-0-6-33	2
VBS-9263-0-6-02	15	VBS-9263-0-6-35	8
VBS-9263-0-6-03	25	VBS-9263-0-6-36	10
VBS-9263-0-6-04	40	VBS-9263-0-6-37	20
VBS-9263-0-6-05	38	VBS-9263-0-6-38	30
VBS-9263-0-6-06	48	VBS-9263-0-6-39	35
VBS-9263-0-6-31	1	VBS-9263-0-6-45	50

## Temperature/Pressure Ratings

See Figure-2 for temperature and pressure ratings. Consult the appropriate valve linkage general instruction sheet for the effect of valve body ambient temperatures on specific actuators. Ratings conform with published values and disclaimer.

### VBS-9263-0-6-P (Screwed Stainless Steel Body)

*Standards:* Pressure to ANSI B16.15 Class 250 with 400 psig up to 150°F

*Materials:* Bronze, ASTM B584

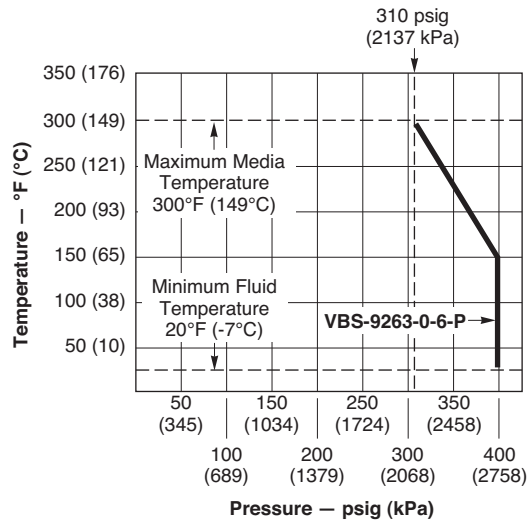

Figure-2 Temperature and Pressure Ratings for VBS-9263 Series Valve Bodies.

# VALVE SIZING AND SELECTION

## Water

### Two-position

Two-position control valves are normally selected “line size” to keep pressure drop at a minimum. If it is desirable to reduce the valve below line size, then 10% of “available pressure” (that is, the pump pressure differential available between supply and return mains with design flow at the valve location) is normally used to select the valve.

### Proportional

Proportional control valves are usually selected to take a pressure drop equal to at least 50% of the “available pressure.” As “available pressure” is often difficult to calculate, the normal procedure is to select the valve using a pressure drop at least equal to the drop in the coil or other load being controlled (except where small booster pumps are used) with a minimum recommended pressure drop of 5 psi (34 kPa). When the design temperature drop is less than 60°F (33°C) for conventional heating systems, higher pressure drops across the valve are needed for good results (Table-4).

**Table-4 Conventional Heating System.**

Design Temperature Load Drop °F (°C)	Recommended Pressure Drop <sup>a</sup> (% of Available Pressure)	Multiplier on Load Drop
60 (33) or More	50%	1 x Load Drop
40 (22)	66%	2 x Load Drop
20 (11)	75%	3 x Load Drop

<sup>a</sup> Recommended minimum pressure drop = 5 psi (34 kPa).

**Secondary Circuits with Small Booster Pumps:** 50% of available pressure difference (equal to the drop through load, or 50% of booster pump head).

### Water Capacity

See Table-5 for water capacity of VBS-9263 series valves.

**Table-5 Water Capacity in Gallons Per Minute for VBS-9263 Series.**

Valve Body Part Number	C <sub>v</sub> Rating	Differential Pressure (ΔP in psi)												
		1	2	3	4	5	6	7	8	9	10	15	20	35
VBS-9263-0-6-31	0.10	0.10	0.14	0.17	0.20	0.22	0.24	0.26	0.28	0.30	0.32	0.39	0.45	0.59
VBS-9263-0-6-33	0.22	0.22	0.31	0.38	0.44	0.49	0.54	0.58	0.62	0.66	0.70	0.85	0.98	1.30
VBS-9263-0-6-01	0.4	0.40	0.57	0.69	0.80	0.89	0.98	1.06	1.13	1.20	1.26	1.55	1.79	2.37
VBS-9263-0-6-35	0.75	0.75	1.06	1.30	1.50	1.68	1.84	1.98	2.1	2.3	2.4	2.9	3.4	4.4
VBS-9263-0-6-36	0.95	0.95	1.34	1.65	1.90	2.12	2.3	2.5	2.7	2.9	3.0	3.7	4.2	5.6
VBS-9263-0-6-02	1.3	1.30	1.84	2.3	2.6	2.9	3.2	3.4	3.7	3.9	4.1	5.0	5.8	7.7
VBS-9263-0-6-37	1.75	1.75	2.5	3.0	3.5	3.9	4.3	4.6	4.9	5.3	5.5	6.8	7.8	10.4
VBS-9263-0-6-03	2.2	2.2	3.1	3.8	4.4	4.9	5.4	5.8	6.2	6.6	7.0	8.5	9.8	13.0
VBS-9263-0-6-38	2.80	2.80	3.96	4.85	5.6	6.3	6.9	7.4	7.9	8.4	8.9	11	13	16.6
VBS-9263-0-6-39	3.25	3.25	4.60	5.63	6.5	7.3	8.0	8.6	9.2	9.8	10.3	13	15	19.2
VBS-9263-0-6-04	3.6	3.60	5.09	6.2	7.2	8.0	8.8	9.5	10	10.8	11.4	14	16	21.3
VBS-9263-0-6-45	4.3	4.3	6.1	7.4	8.6	10	11	11	12	12.9	13.6	17	19	25.4
VBS-9263-0-6-05	5.0	5.0	7.1	8.7	10	11	12	13	14	15.0	15.8	19	22	29.6
VBS-9263-0-6-06	6.2	6.2	8.8	11	12	14	15	16	18	18.6	19.6	24	28	36.7

### C<sub>v</sub> Equation

$$C_v = \frac{\text{GPM}}{\sqrt{\Delta P}} \quad \Delta P = \left( \frac{\text{GPM}}{C_v} \right)^2 \quad \text{GPM} = C_v \sqrt{\Delta P}$$

Where:

C<sub>v</sub> = Coefficient of flow

GPM = U.S. gallons per minute (60°F, 15.6°C)

ΔP = Differential pressure in psi (pressure drop)

# Steam

## Two-position

Two-position zone valves and direct radiation valves are normally sized using a minimum of 10% of inlet pressure (psig).

## Proportional

Proportional control valves are normally sized using:

- For low pressure (15 psig or less), use  $\Delta P$  of 80% of gauge inlet pressure.
- For steam pressures greater than 15 psig, use  $\Delta P$  of 42% of absolute (gauge plus 14.7) inlet pressure.
- When the  $C_v$  required is between two valve sizes, select the larger size. Do not size steam valves using a pressure drop greater than 42% of the absolute inlet pressure.

## Steam Capacity

See Table-6 for steam capacity of VBS-9263 series valves.

**Table-6 Steam Capacity in Pounds Per Hour for VBS-9263 Series.**

Valve Body Part Number	$C_v$ Rating	Differential Pressure ( $\Delta P$ in psi) <sup>a</sup>															
		2 psig Inlet		5 psig Inlet		10 psig Inlet		15 psig Inlet		20 psig Inlet		25 psig Inlet		30 psig Inlet		35 psig Inlet	
		0.2	1.6	0.5	4	1	8	1.5	12	2	14	2.5	16	3	18	3.5	20
VBS-9263-0-6-31	0.10	0.5	1.5	0.9	2.4	1.5	3.5	2.0	4.4	2.4	5.1	2.9	5.8	3.4	6.6	3.8	7
VBS-9263-0-6-33	0.22	1.2	3.2	2.0	5	3.2	8	4.3	10	5	11	6	13	7	14	8	16
VBS-9263-0-6-01	0.4	2.2	6	4	10	6	14	8	17	10	20	12	23	13	26	15	29
VBS-9263-0-6-35	0.75	4	11	7	18	11	26	15	33	18	38	22	44	25	49	29	55
VBS-9263-0-6-36	0.95	5	14	9	23	14	33	19	42	23	49	27	55	32	62	36	69
VBS-9263-0-6-02	1.3	7	19	12	31	19	45	25	57	32	66	38	76	44	85	50	95
VBS-9263-0-6-37	1.75	10	26	16	42	26	61	34	77	42	89	51	102	59	115	67	128
VBS-9263-0-6-03	2.2	12	32	20	52	32	76	43	96	53	112	64	129	74	145	84	161
VBS-9263-0-6-38	2.80	15	41	26	67	41	97	55	122	68	143	81	164	94	184	107	205
VBS-9263-0-6-39	3.25	18	48	30	77	47	113	63	142	79	166	94	190	109	214	124	238
VBS-9263-0-6-04	3.6	20	53	33	86	53	125	70	157	87	184	104	210	121	237	137	263
VBS-9263-0-6-45	4.3	23	63	40	102	63	149	84	188	104	220	124	251	144	283	164	314
VBS-9263-0-6-05	5.0	27	74	46	119	73	173	98	219	121	255	145	292	168	329	191	366
VBS-9263-0-6-06	6.2	34	91	58	147	91	215	121	271	150	317	179	362	208	408	237	453

<sup>a</sup> Values are for saturated steam ( $K = 1$ ). Left column under each inlet pressure is for two-position control, and right column is for proportional control.

## $C_v$ Equation

$$C_v = \frac{QK}{3\sqrt{\Delta P \cdot P_2}} \quad Q = \frac{3C_v\sqrt{\Delta P \cdot P_2}}{K}$$

Where:

$C_v$  = Coefficient of flow

$Q$  = Lbs. per hour of steam

$\Delta P$  = Differential pressure in psi (pressure drop)

$P_2$  = Outlet pressure in psia (absolute) ( $P_2 = \text{Inlet pressure} + 14.7 - \Delta P$ )

$K$  =  $1 + (0.0007 \times \text{°F superheat})$  ( $K = 1$  for saturated steam)

## Cavitation Limitations on Valve Pressure Drop

A valve selected with too high a pressure drop can cause erosion of discs and/or wire drawing of the seat. In addition, cavitation can cause noise, damage to the valve trim (and possibly the body), and choke the flow through the valve.

Do not exceed the maximum differential pressure (pressure drop) for the valve selected.

The following formula can be used on higher temperature water systems, where cavitation could be a problem, to estimate the maximum allowable pressure drop across the valve:

$$P_m = 0.5 (P_1 - P_v)$$

Where:

$P_m$  = Maximum allowable pressure drop (psi)

$P_1$  = Absolute inlet pressure (psia)

$P_v$  = Absolute vapor pressure (psia) (refer to Table-6 or Table-7)

---

*Note:* Add 14.7 psi to gauge supply pressure to obtain absolute pressure value.

---

For example, if a valve is controlling 200°F water at an inlet pressure of 18 psig, the maximum pressure drop allowable would be:

$$P_m = 0.5 [(18 + 14.7) - 11.53] = 10.6 \text{ psi}$$

(Vapor pressure of 200°F water is 11.53 psia.)

If the pressure drop for this valve is less than 10.6 psi, cavitation should not be a problem.

Systems where cavitation is shown to be a problem can sometimes be redesigned to provide lower inlet velocities.

**Table-7 Vapor Pressure of Water Table.**

Water Temp. (°F)	Vapor Pressure (psia)	Water Temp. (°F)	Vapor Pressure (psia)	Water Temp. (°F)	Vapor Pressure (psia)	Water Temp. (°F)	Vapor Pressure (psia)
40	0.12	90	0.70	140	2.89	190	9.34
50	0.18	100	0.95	150	3.72	200	11.53
60	0.26	110	1.28	160	4.74	210	14.12
70	0.36	120	1.69	170	5.99	220	17.19
80	0.51	130	2.22	180	7.51	230	20.78

## Additional Valve Sizing Information

For additional valve sizing information, see:

- CA-28 Control Valve Sizing, F-13755
- Valve Sizing Slide Rule, TOOL-150

# INSTALLATION

## Inspection

Inspect the package for damage. If damaged, notify the appropriate carrier immediately. If undamaged, open the package and inspect the device for obvious damage. Return damaged products.

## Requirements

- Tools (not provided): Pipe wrenches
- Training: Installer must be a qualified, experienced technician
- Appropriate accessories

---

**Caution:**

- Install the valve with the flow in the direction of the flow arrow (“A” port is the inlet and “AB” port is the outlet).
  - Do not exceed the ratings of the device.
  - Avoid locations where excessive moisture, corrosive fumes, or vibration are present.
- 

## Mounting

1. The valve should be mounted in a weather-protected area in a location that is within the ambient limits of the actuator. When selecting a location, allow sufficient room for valve linkage, actuator, and other accessories and for service of the product.
2. The preferred mounting position for the valve is with the valve stem vertical above the valve body. Avoid mounting the valve so that the valve stem is below horizontal.
3. On steam applications where the ambient temperature approaches the limit of the actuator, the valve stem should be mounted 45° from vertical.
4. The valves must be piped with the “A” port as the inlet and the “AB” port as the outlet.

### Screwed Valve Bodies

The VBS-9263 series screwed valve bodies conform to American Standard Taper Pipe Threads (NPT).

1. Apply pipe dope sparingly to all but the last two threads of a properly threaded, reamed, and cleaned pipe. Make sure that pipe chips, scale, etc. do not get into the pipe since this material may lodge in the valve seat and prevent proper closing and opening of the valve.
2. Start the joint by hand screwing the pipe into the valve. If the thread engagement feels “right,” turn the pipe by hand as far as it will go.
3. Use a pipe wrench to fully tighten the valve to the pipe. Do not over tighten or strip threads. See Table-8 and Figure-3 for the normal engagement length of the threads. Figure-4 shows a means of tightening the pipe so that the valve is not twisted or crushed.

**Table-8 Normal Thread Engagement Between Male Pipe Thread and Valve Body.**

Valve Size Inches (NPT)	Normal Engagement
1/2"	1/2"
3/4"	9/16"

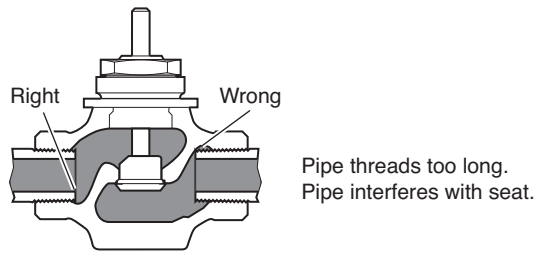

Figure-3 Normal Thread Engagement.

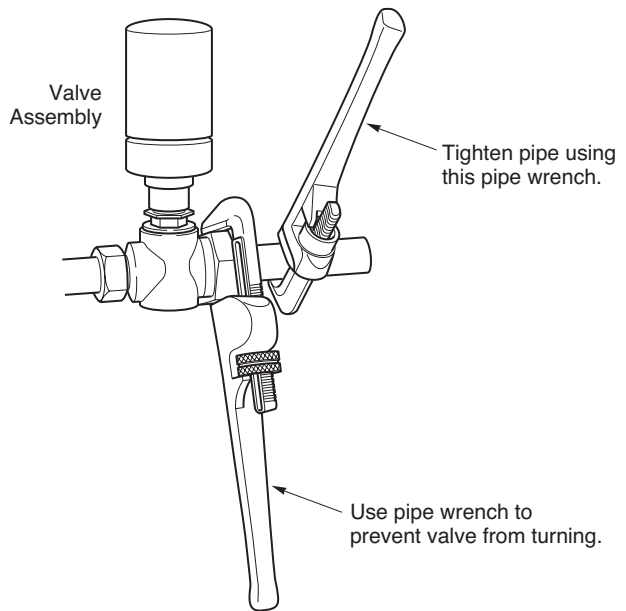

Figure-4 Installation of Screwed End Valves.

## CHECKOUT

1. Make sure the valve stem operates smoothly before installing the valve linkage and the actuator.
2. If the stem does not operate smoothly, it may indicate that the valve was twisted or crushed during installation or that the stem was bent by rough handling. These conditions may require that the valve be replaced.
3. After the piping is under pressure, check the valve body and the connections for leaks.
4. After the valve linkage and the actuator are installed, check their operation.

## MAINTENANCE & FIELD REPAIR

Regular maintenance of the total system is recommended to assure sustained performance. See Table-9 for maintenance kit part numbers.

**Table-9 Maintenance Kits for VBS-9263 Valves.**

Valve Body Part Number	Replacement Packing Assembly	Packing Wrench	Valve Repair Kit <sup>a</sup>
VBS-9263-0-6-01	YBA-622-316	TOOL-20-1	RYBS-9263-1
VBS-9263-0-6-02			RYBS-9263-2
VBS-9263-0-6-03			RYBS-9263-3
VBS-9263-0-6-04			RYBS-9263-4
VBS-9263-0-6-05			RYBS-9263-5
VBS-9263-0-6-06			RYBS-9263-6
VBS-9263-0-6-31			RYBS-9263-31
VBS-9263-0-6-33			RYBS-9263-33
VBS-9263-0-6-35			RYBS-9263-35
VBS-9263-0-6-36			RYBS-9263-36
VBS-9263-0-6-37			RYBS-9263-37
VBS-9263-0-6-38			RYBS-9263-38
VBS-9263-0-6-39			RYBS-9263-39
VBS-9263-0-6-45			RYBS-9263-45

<sup>a</sup> Kit includes replacement packing and stem & plug assembly.

## Water System Maintenance

All heating and cooling systems are susceptible to valve and system problems caused by improper water treatment and system storage procedures. These guidelines are provided to help avoid valve and water system problems resulting from improperly treated water or storage procedures in cooling and hot water systems, and to obtain maximum life from TAC valves.

Durability of valve stems and packings is dependent on maintaining non-damaging water conditions. Inadequate water treatment or filtration, not in accordance with chemical supplier/ASHRAE handbook recommendations, can result in corrosion, scale, and abrasive particle formation. Scale and particulates can result in stem and packing scratches and can adversely affect packing life and other parts of the hydronic system.

To maintain non-damaging conditions, follow these guidelines:

- Clean the system prior to start up. Use a nitrite or molybdate-based treatment program.
- Use filtration equipment where needed.
- Properly store off-line systems and monitor water treatment results using corrosion test coupons.
- Follow the advice of a water treatment professional.
- Consult **EN-205, Water System Guidelines Engineering Information, F-26080**, for further details.

# DIMENSIONAL DATA

**Table-10 Dimensions for VBS-9263 Series Valves (Figure-5).**

Part Number	Valve Size	Dimensions in Inches (mm)				
		A	B	C	D (Stem Down)	E <sup>a</sup> (Stroke)
VBS-9263-0-6-P	1/2"	3 (76)	1-27/64 (36)	1-1/16 (27)	25/32 (20)	1/2 (13)
	3/4"	3-19/32 (91)	1-37/64 (40)	1-13/32 (36)		

<sup>a</sup> Add up to 1/16 in. (1.6 mm) for disc seating and compression.

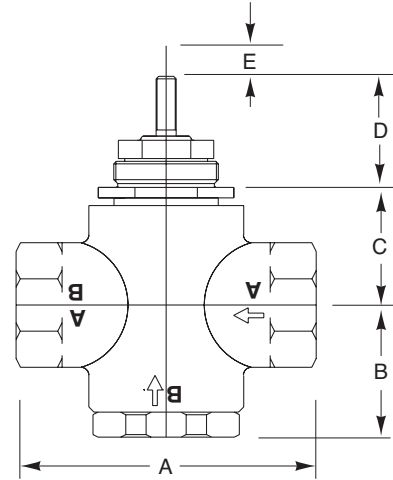

Figure-5 Typical of VBS-9263-0-6-P Valve Bodies.

---

Copyright 2008, TAC  
All brand names, trademarks and registered  
trademarks are the property of their respective  
owners. Information contained within this  
document is subject to change without notice.

F-26418-2

**TAC**  
1354 Clifford Avenue  
P.O. Box 2940  
Loves Park, IL 61132-2940  
[www.tac.com](http://www.tac.com)

**t.a.c.** <sup>®</sup>  
by **Schneider Electric**