

**Pneumatic Zero Energy Band
Room Thermostats
General Instructions**

APPLICATION

For proportional control of pneumatically-operated sequenced heating and cooling valves and/or damper actuators to maintain room air temperature with a zero energy band between heating and cooling in heating, ventilating and air conditioning systems.

SPECIFICATIONS

Thermostat: Proportional two pipe type. Thermostat maintains constant branch pressure when temperature is between dial setpoints.

Sensing Elements: Two bimetals.

Control Dial Range: Two independent with stops, see Table 1.

Throttling Range: Adjustable 2 to 10 °F/10 psi change in branch pressure when temperature is not between dial setpoints, factory set at 4 °F/10 psi.

Output Air Signal: 0.5 psig (3.4 kPa) to supply air pressure -0.5 psig (-3.4 kPa).

Zero Energy Band Pressure: Adjustable 5 to 11 psig (34 to 76 kPa) factory set at 8 psig (55 kPa).

Action: See Table 1.

Ambient Limits:

Shipping, -40 to 150 °F (-40 to 65 °C). 0 to 98% R.H., non-condensing.

Operating, 20 to 115 °F (-7 to 46 °C). 10 to 98% R.H., non-condensing.

Supply Air Pressure: Clean, oil free, dry air required (reference EN-123).

Nominal, 20 psig (138 kPa).

Minimum, 15 psig (103 kPa).

Maximum, 30 psig (207 kPa).

Air Connections:

Main (Black), 5/32" dia. spring reinforced plastic tube.

Branch (white), 5/32" dia. spring reinforced plastic tube.

Air Consumption for Sizing Air Compressor:

TK-18x1, TKR-18x1, 0.012 scfm (5.7 ml/s).

TK-18x1-600 (Aspirated models), 0.028 scfm (13.2 ml/s).

Air Capacity for Sizing Air Mains:

TK-18x1, TKR-18x1, 16 scim (4.4 ml/s).

TK-18x1-600, 56 scim (15.3 ml/s).

Cover: Beige plastic with brushed bronze metal insert as standard except aspirated models. Aspirated models have brushed stainless steel covers.

Mounting: Upright position on wall.

Dimensions:

TK-18x1, TKR-18x1, 4-3/8" high x 2-3/4" wide x 1-5/8" deep (111 mm x 70 mm x 43 mm).

TK18x1-600, Wall box — 5" high x 3-1/2" wide x 2-1/2" deep (127 mm x 89 mm x 64 mm).

Cover — 5-1/2" high x 4" wide (140 mm x 102 mm).

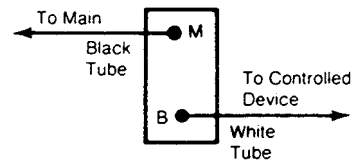
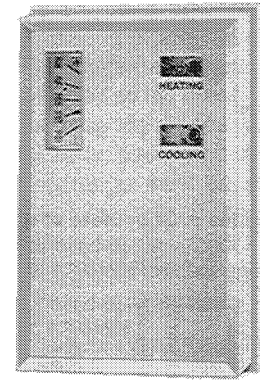

Figure-1

Table-1 SPECIFICATIONS.

Application	Control Action*	Part Number	
		Dial Range**	
		55 to 85 °F	13 to 29 °C
N.O. Heat N.C. Cool	Direct	TK-1801 TKR-1801	TK-1801-116
N.C. Heat N.O. Cool	Reverse	TK-1811 TKR-1811	TK-1811-116

*Direct Acting (D.A.) - Increase output pressure on temperature rise.

Reverse Acting (R.A.) - Decrease output pressure on temperature rise.

**Control dial marked °F on one side and °C on the other side; built-in dial stops can limit high and/or low setting of each dial.

Table-2 TKR-18X1 INCLUDES:

Quantity	Description
1	TK-18X1 thermostat
1	Blank cover insert
1	Cover insert with setpoint cutout
2	1/4" x 5/32" barbed fitting
2	5/32" x 5/32" barbed fitting
2	1/4" O.D. x 2" Tygon tubing
2	1/4" x 1/4" compression to tubing fitting
1	5/64" Allen head cover screw
1	5/64" Allen head wrench

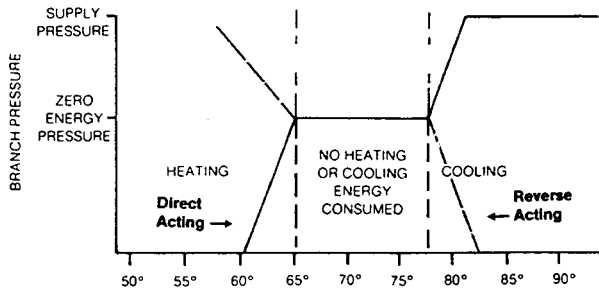
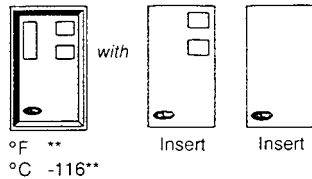

Figure-2

STANDARD



Aspirated model (requires AT-509) **Note:** Not available on TKR-18X1 models.
 -600

Options (For quantities of 24 or more of same part number)

Add "dash number" (-XXX) suffix to base part number for desired option. For metal covers, specify TK2-18X1-XXX.

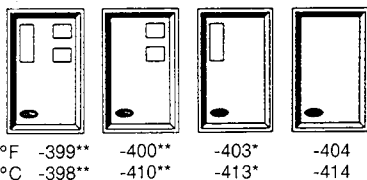

*Units have external thermometers.
 **Units have internal setpoint adjustment; setpoint can be seen externally. Knobs are provided to modify the unit to external adjustment.

ACCESSORIES

- AT-65 Series Cover inserts
- AT-85 Series Digital thermometer cover kit, plastic cover
- AT-95 Series Digital thermometer cover kit, metal cover
- AT-504 Plaster hole cover
- AT-505 Surface mounting base
- AT-506 Pneumatic wall box fitting
- AT-509 Wall box required for aspirated thermostats
- AT-536 Pneumatic wall thermostat conversion kit
- AT-546 Auxiliary mounting base
- AT-1100 Series Thermostat guards
- AT-533-101 Adapter 1/4" plastic to 5/32" plastic
- AT-533-127 Adapter 3/16" copper or 1/4" copper with 1/4" solder coupling (not included) to 5/32" plastic
- PKG-1093 Digital thermometer battery replacement kit
- TOOL-15 Spanner head driver
- TOOL-80-1 Changeover/dial
- TOOL-95-1 Pneumatic calibration tool kit

PRE-INSTALLATION

The thermostats are shipped with mounting screws. Wall fittings must be ordered separately.

Before installation, make a visual inspection of the thermostat carton for obvious signs of damage.

Air Connections:

Two plastic tubes reinforced with a coil spring are coded M and B. The M (black) designates the supply main and the B (white) designates the controlled branch line. See Figure 1.

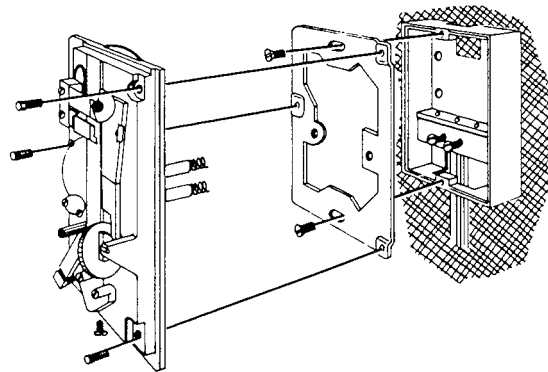

Figure-3 Typical Mounting Thermostat to AT-506 Wall Box Fitting.

INSTALLATION

Requirements

Locate the thermostat where it will be exposed to unrestricted circulation of air which represents the average temperature of the controlled space. Do not locate the thermostat near sources of heat or cold such as lamps, motors, sunlight, or concealed ducts or pipes.

The thermostat fitting is available for either flush or surface mounting. See Figures 3 and 4. Use the AT-506 wall box fitting for surface mounting on all wall surfaces and flush mounting on plastered or stud walls.

Procedure

To mount a thermostat on an AT-506 wall box fitting, refer to Figure 3.

1. Remove and discard the cardboard cover plate on the wall box. (The cardboard cover protects the fitting while the wall is being plastered.)
2. Fasten the mounting plate to the wall box with the two flat headscrews provided. Make sure it is square with the wall before tightening the screws.
3. If the thermostat tubing is too long for easy coiling in the wall box, it can be cut to length. Cut the tubing at a 45° angle for ease of inserting the tubing into the "O" ring seal. Be sure that the coil spring is cut flush with the tubing.
4. Remove and discard the short piece of tubing from the connector head of the wall box.
5. Insert the main (black) plastic tubing into the left-hand hole in the connector head. Insert the branch line (white) tubing into the right-hand hole in the connector. Insert tubes at least 1/4". Do not use any lubricant on the plastic tubing.
6. Fasten the thermostat to the mounting plate with the three Allen mounting screws provided. Tighten the screws evenly.

To mount a thermostat on an electrical switch box, refer to Figure 4

1. Attach the mounting plate to the switch box with the two flathead screws provided. Be sure the mounting plate is vertical.
2. Slightly rotate the tubes back and forth, and push firmly onto the fittings. (See Figure 5)
3. Fasten the thermostat to the mounting plate with the Allen head screws provided and tighten evenly.

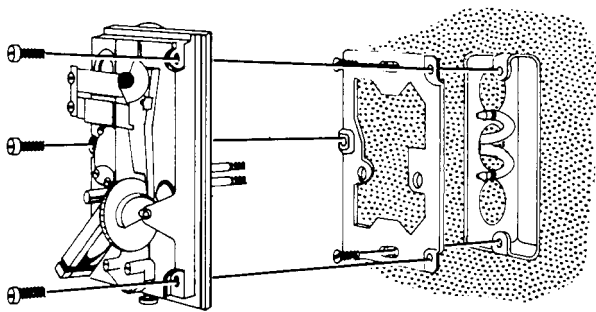

Figure-4 Typical Mounting Thermostat to Electric Box.

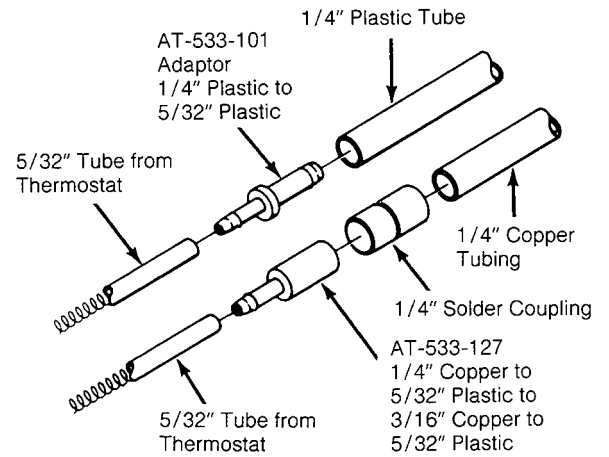

Figure-5

For installation of external setpoint, refer to figure 6

1. Insert the knob through hole in cover. The knob should rest on the calibration screw with the slots aligned with the dial clamp screws.
2. Insert screw supplied with the knob into the center of the knob and tighten, being careful not to disturb the setting of the calibration screw.

Note: The knob must be removed in order to remove thermostat cover or recalibrate thermostat.

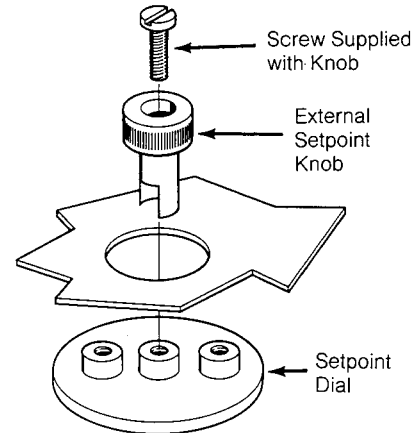

Figure-6

CHECKOUT

After installing the thermostat, verify proper operation.

Note: If external setpoint knobs are installed, use TOOL-80-1 to turn setpoint dials (thermostat cover must be removed).

1. Measure the ambient temperature near the thermostat with an accurate thermometer. The ambient should be stable and between 60 and 80 °F (16 and 27 °C) to effectively check thermostat operation.
2. Check the Zero Energy Band (ZEB) pressure. Set the heating dial to 55 °F (13 °C) and the cooling dial to 85 °F (29 °C). Branch pressure should equal the ZEB pressure, which is factory set at 8 psi. The ZEB pressure should be between the spring ranges of the actuators being controlled. If a ZEB pressure other than what is observed is required, see ADJUSTMENTS.
3. Check thermostat operation. Slowly increase the setting of the heating dial. When the dial setting exceeds the ambient temperature, branch pressure should fall if the unit is direct acting (TK-1801) or rise if the unit is reverse acting (TK-1811). Reset the heating dial to 55 °F (13 °C) and slowly lower the setting of the cooling dial. When the dial setting falls below the ambient temperature, branch pressure should rise if the unit is direct acting or fall if the unit is reverse acting.

Note: The amount of rise or drop in branch pressure may vary depending on the throttling range setting of the thermostat and the ambient temperature in the test area. If the branch pressure is always 0 psig (0kPa), the restriction may be plugged. If the branch pressure is always equal to supply or unable to be decreased below 3 psig (21 kPa), the nozzle may be plugged.

4. Check for active heating thermal element. Set the cooling dial to 85 °F (29 °C). Vary the setting of the heating dial to obtain a branch pressure of approximately 3 psig (21 kPa) on a direct acting unit (TK-1801) or 12 psig (82 kPa) on a reverse acting unit (TK-1811). Slightly warm the element with your hand or breath. Branch pressure should increase on a direct acting unit or decrease on a reverse acting unit.

5. Check for active cooling thermal element. Set the heating dial to 55 °F (29 °C). Vary the setting of the lower cooling dial until a branch pressure of approximately 12 psig (82 kPa) on a direct acting unit or 3 psig (21 kPa) on a reverse acting unit is obtained. Slightly warm the element with your hand or breath. Branch pressure should increase on a direct acting unit or decrease on a reverse acting unit.

Refer to **CALIBRATION** if the thermostat fails to function properly.

System Checkout

After thermostat operation has been checked, check system operation as follows:

1. Set the heating dial at 55 °F (13 °C) and the cooling dial at 85 °F (29 °C). The ambient temperature at the thermostat should be stable and between 60 and 80 °F (16 and 27 °C).
2. Verify that both the heating and cooling media are off (or at minimum, depending on system design). If one or both are energized, contrary to system design, the use of positive positioners on the heating and/or cooling actuators can overcome this problem. Alternatively, a 1:2 ratio relay in the branch line to the heating and/or cooling actuators can be used. Note that this will affect the system throttling range, and that adjustments of the thermostat throttling range may be required.
3. Slowly increase the setting of the heating dial. When the dial setting exceeds the ambient temperature, the heating medium should be energized. Reset the dial at 55 °F (13 °C).
4. Slowly decrease the cooling dial setting. When the dial setting falls below ambient temperature, the cooling medium should be energized.
5. Set the heating and cooling dials to their desired setpoints.

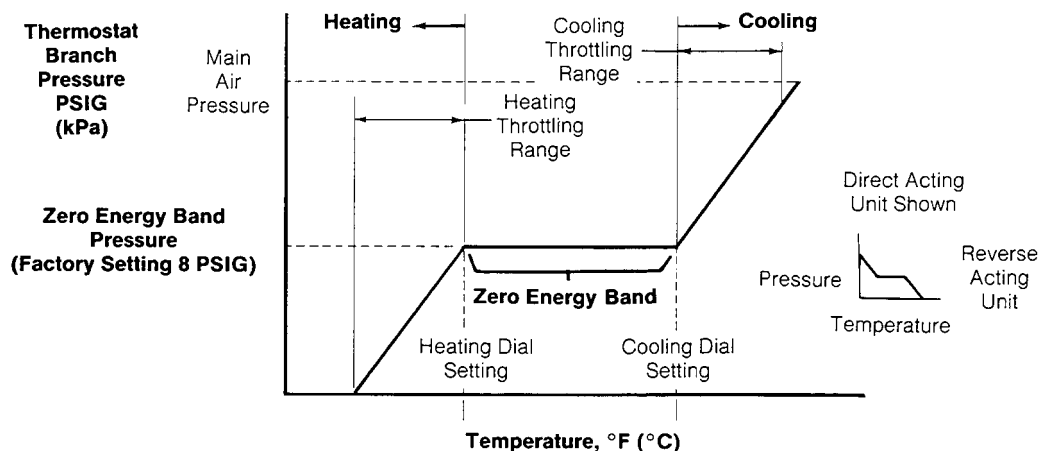

Figure-7

ADJUSTMENTS

Zero Energy Band Pressure

The Zero Energy Band (Z.E.B.) pressure (see Figure 7) is factory set at 8 psig (55 kPa). To check this setting, refer to Step 1 below. This pressure should be set midway between the pressure ranges of the heating and cooling actuators in order to obtain proper sequencing, and the actuator ranges should be separated by a minimum of 2 psi (more if possible). If a Z.E.B. pressure other than the factory setting is desired, proceed as follows:

1. Set the heating dial at 55 °F (13 °C) and the cooling dial at 85 °F (29 °C). Ambient temperature should be between 60 and 80 °F (16 and 27 °C). The resulting branch pressure is the Z.E.B. pressure. To increase this setting, turn the calibrating screw counterclockwise (see Figure 8).
2. Check the calibration of both dials (see CALIBRATION).

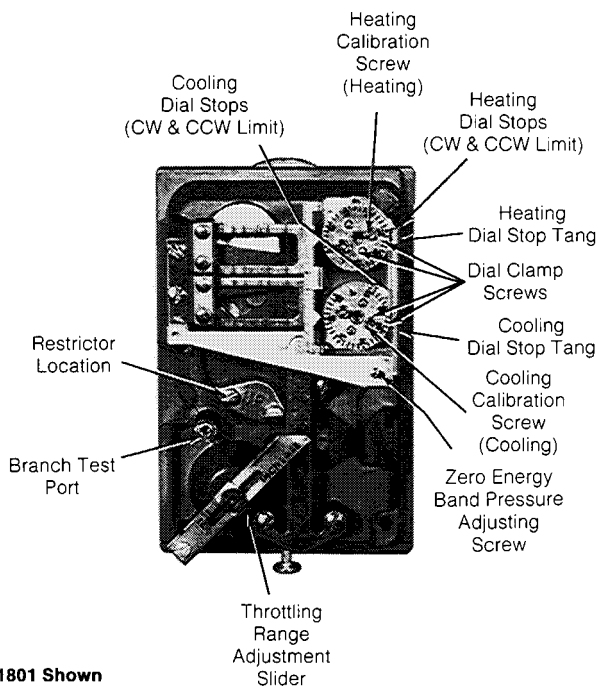

TK-1801 Shown

NOTE: Upper Dial is Cooling Dial and Lower Dial is Heating Dial on TK-1811.

Figure-8

Throttling Range

Throttling range is factory set at 4 °F per 10 psi (2 °C per 62 kPa) change. If the throttling range setting is too wide, excessive offset or droop will be encountered and the throttling range should be decreased. If the throttling range is too narrow, system cycling or hunting will occur and the throttling range should be increased. If stable control cannot be obtained, check system component sizing, sensor location, and system response time as possible causes. The thermostat throttling range should be set at the lowest value which will allow the thermostat to control the system without cycling under normal load conditions.

Note: The throttling range of the thermostat is divided equally between heating and cooling. If the thermostat throttling range is set at 4 °F, the throttling range is 2 °F for heating and 2 °F for cooling (see Figure 7).

To check the throttling range

1. Ambient temperature, as measured by an accurate thermometer, should be stable and between 60 and 80 °F (16 and 27 °C).
2. Set the upper dial at 55 °F (13 °C) and the lower dial at 85 °F (29 °C) and note the Z.E.B. pressure.
3. Slowly increase the setting of the upper dial until the branch pressure begins to change and note the dial setting. Continue to increase the setting until branch pressure reaches 3 psig (21 kPa) on direct acting models or 13 psig (89 kPa) on reverse acting models. The total throttling range is:

$$\frac{\text{Difference in Dial Stops, } ^\circ\text{F}}{\text{Change in Branch Pressure, psi}} \times 10$$

or $\frac{(\text{Difference in Dial Settings, } ^\circ\text{C})}{\text{Change in Branch Pressure, kPa}} \times 68.5$

To adjust the throttling range

1. Move the throttling range adjustment slider in the required direction (see Figure 8).
2. Readjust the Z.E.B. pressure (see Zero Energy Band Pressure).
3. Check the calibration of both dials (see CALIBRATION).

Adjustment of Dial Stops

To set the setpoint dial stops, proceed as follows:

1. Using the TOOL-82 5/64" Allen wrench, loosen the two dial clamp screws approximately 1/2 turn.
2. Separate the two dial stop tabs if not already separated.
3. Using the TOOL-82 5/64" Allen wrench, turn the setpoint dial to the desired clockwise dial limit. While holding the dial with the Allen wrench, slide one stop tab in a clockwise direction until it touches the top side of the stop tang.
4. Rotate the setpoint dial to the counterclockwise limit. While holding the dial with the 5/64" Allen wrench, rotate the other stop tab counterclockwise to touch the bottom of the stop tang.
5. Carefully tighten the dial screws with the TOOL-82 5/64" Allen wrench.
6. Rotate setpoint dial from counterclockwise stop to clockwise stop to check the stop settings. Repeat adjustment steps if necessary.

Note: Stops can be rotated to lock setpoint dial in one place if desired.

Converting Dials to °C

To convert the unit from °F dial reading to °C dial reading, proceed as follows:

1. Rotate setpoint dial clockwise to end of dial scale.
2. While holding dial, use the TOL-82 5/64" Allen wrench to remove the dial screws.
3. Carefully remove dial plate and turn over. Make sure stop tab plates and clamp ring are in place.
4. Align dial plate to read clockwise end of °C scale.
5. Carefully re-install dial screws. Do not tighten.
6. Readjust stop tabs (see Adjustment of Dial Stops).

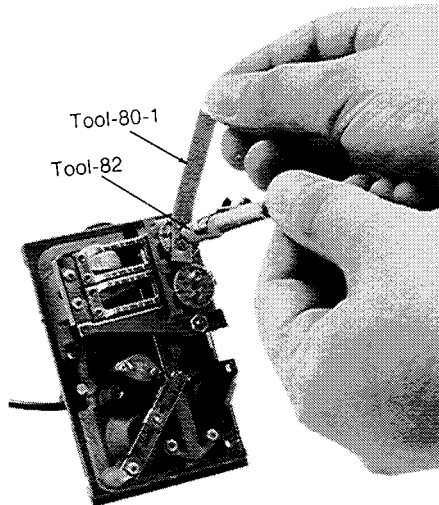

Figure-9

CALIBRATION

As a nominal calibration, the branch line control pressure should be the Zero Energy Band pressure (factory set at 8.0 psig) when the setpoint is equal to the ambient temperature as measured by an accurate thermometer. This means that when space temperature is between the two dial settings, both heating and cooling are off. It also means that the heating and cooling throttling ranges are offset above and below their respective dial settings (see Figure 7). If desired, the thermostat can be calibrated so the branch pressure equals the center of the actuator spring ranges when ambient temperature equals setpoint. Note, however, that in the case the total thermostat throttling range must be subtracted from the Zero Energy Band. For example, if the heating setpoint is 65 °F (18 °C), the cooling setpoint is 78 °F (26 °C), and the throttling range is 6 °F (3 °C), the Zero Energy Band is 78 °F minus 65 °F minus 3 °F or 10 °F (6 °C) total.

When checking or changing the calibration of the heating dial, set the cooling dial at 85 °F (29 °C). Likewise, when checking or changing the calibration of the cooling dial, set the heating dial at 55 °F (13 °C).

Caution: The thermal element of the room thermostat is very sensitive to temperature change. Do not effect its temperature by touching the bimetal or breathing on the thermostat. When calibrating the instrument, observe the wall box temperature frequently and reset the setpoint dial if

required.

Procedure

1. Remove the thermostat cover by loosening the cover screw.
2. Check the Zero Energy Band pressure setting of the thermostat per CHECKOUT, step 2.
3. Using the TOOL-82 5/64" Allen wrench, unscrew (counterclockwise rotation) the branch test port one full turn (see Figure 8).
4. Attach the test gauge rubber seal to the boss. Using a rotary motion, push the gauge on as far as it will go [1/4" (6mm) minimum]. The tubing will support the test gauge in a position where it can be easily read.
5. Adjust the dial being calibrated to the measured ambient temperature. The other dial should be set at the end of its range (low end for heating, high end for cooling).
6. Using TOOL-80-1 to prevent the dial from rotating, use the TOOL-82 0.048" six-spline wrench to adjust the dial calibrating screw (see Figure 9) until branch pressure equals the Z.E.B. pressure (or alternatively the mid-range pressure of the actuator being controlled).
7. Reset the dial to the end of its range (low end for heating, high end for cooling), and repeat steps 5 and 6 for the other dial if required.
8. Return both dials to their nominal settings, remove the test gauge, turn the branch test gauge screw clockwise to tighten, and replace the cover.

Cover Insert Installation (see Figure 10)

1. Select appropriate cover insert.
2. Remove protective backing and protective skin on face of cover insert.
3. Press insert uniformly on thermostat with logo in lower left-hand corner.

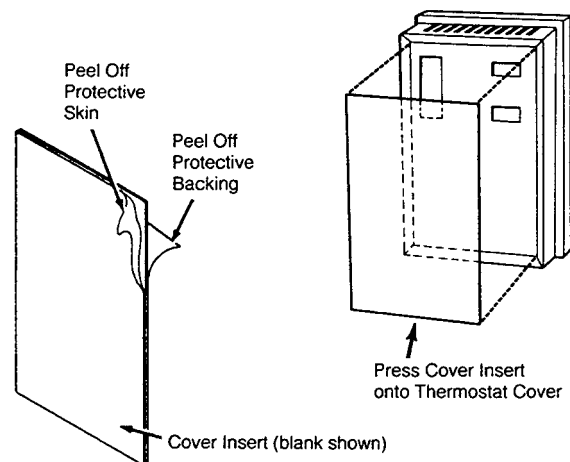

Figure-10 Cover Insert Installation.

MAINTENANCE

This is a quality product. Regular maintenance of the total system is recommended to assure sustained optimum performance. No routine maintenance of this device is required if the system is properly maintained.

REPAIR

Field repair of pneumatic thermostats is not recommended. However, if the thermostat output pressure is 0 and it cannot be corrected by calibration, the restriction should be checked. Hold the restriction plate up to the light and check the 0.0045 hole. If the hole is blocked, the restriction plate must be replaced. The filter should be replaced at the same time. If the hole is not blocked, then the thermostat should be replaced.

Before replacing a thermostat, check to make sure the thermostat is piped per the job wiring diagram. Also check main air pressure, and check for foreign material (dirt, oil, water, etc.) in the air supply. If the air supply is contaminated, remedy this before replacing the thermostat.

Refer to the General Catalog for a complete list of available replacement parts.

Copyright 2008, TAC
All brand names, trademarks and registered
trademarks are the property of their respective
owners. Information contained within this
document is subject to change without notice.

TAC
1354 Clifford Avenue
P.O. Box 2940
Loves Park, IL 61132-2940
www.tac.com

F-20007-5

t.a.c. [®]
by Schneider Electric