



TAC
 1354 Clifford Avenue
 P. O. Box 2940
 Loves Park, IL 61132-2940
 www.tac.com

TC-186
TC-187
TC-188

Two-Position, Zero Energy Band
Electric Room Thermostats
General Instructions

APPLICATION

For on-off control of line voltage fans or valves on heating and cooling fan coil units.

SPECIFICATIONS

- Sensing Element:** Bimetal.
- Electrical Switch:** SPDT switch, zero energy band (neutral center).
- Fan Switch:** Integral two-pole, four position. (See Figure 1 for switching action).
- Connections:** Color coded 6" leads for thermostat and fan switch.
- Cover:** Plastic with metal insert.
- Mounting:** Flush or surface switch box.
- Thermostat Package Contains:** Mounting plate with two screws and dial stop pins.
- Dimensions:** 4-3/8" high x 2-3/4" wide x 1-5/8" deep (111 mm x 70 mm x 41 mm).

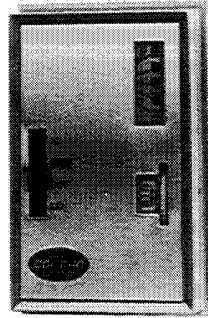

TC-186

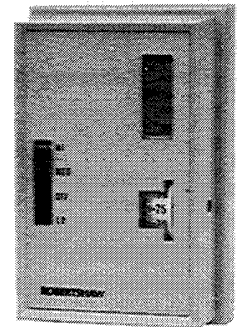

TC-186-770



ACCESSORIES

- | | |
|---------|---|
| AT-101 | Lock cover kit |
| AT-504 | Plaster hole cover kit (small) |
| AT-505 | Surface mounting base |
| AT-546 | Auxiliary mounting base |
| AT-602 | Selector switch sub-base DP4T |
| AT-603 | Selector switch sub-base one DP4T, one DPDT |
| AT-1103 | Wire guard |
| AT-1104 | Cast aluminum guard |
| AT-1105 | Plastic guard |
| AT-1155 | Plastic guard |
| AT-1165 | Plastic guard |
| TOOL-11 | Calibration wrench |

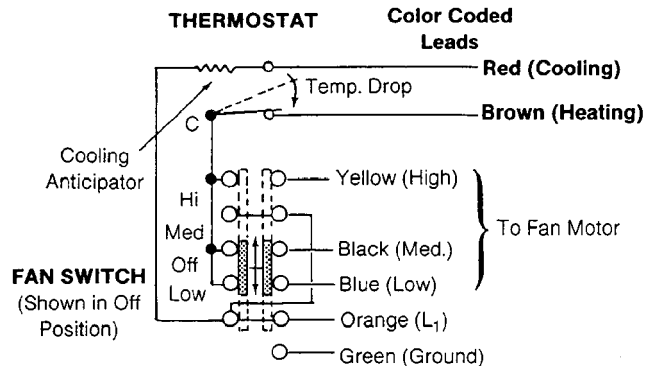

Figure-1 Switch Action and Connections.

Table-1 SPECIFICATIONS.

Part Number	Company Identification	Sequenced Heat & Cool Applications	Control* Dial Range °F (°C)	Thermal Differential °F (°C)	Fan Switch Marking	Electrical Ratings					
						Volts (AC)	Fan Switch		Thermostat Contacts		
							Full Load Amps	Locked Rotor Amps	Full Load Amps	Locked Rotor Amps	Pilot Duty (VA)
TC-186	TAC	24 Volt	55-85 (13-29)	2 (1.1) Heat 2 (1.1) Neutral 2 (1.1) Cool	Low-Off** Med-High	24	6	36	4.4	26	125
TC-186-770	Robertshaw										
TC-187	TAC	120 Volt				120	6	36	4.4	26	
TC-187-770	Robertshaw										
TC-188	TAC	240 Volt				240	3	18	3.0	18	
TC-188-770	Robertshaw										

*Dial stop pins included to limit control range.

**Off position de-energizes thermostat and fan circuits.

PRE-INSTALLATION

Inspection

Inspect the carton for damage. If damaged, notify the appropriate carrier immediately. Inspect the device for obvious damage due to shipping. Return damaged products.

Requirements

- Wiring diagram
- Tools (not provided):
Appropriate screwdriver(s) for cover, terminals and mounting screw.
Appropriate drill and drill bit for mounting screws
Wire cutters and strippers

Caution:

- Installer must be a qualified, experienced technician.
- Make all connections in accordance with electrical wiring diagrams, and in compliance with national and local codes. Use copper conductors only.
- NEMA Type 1 covers are intended for indoor use primarily to provide a degree of protection against contact with the enclosed components.

INSTALLATION

Thermostats require upright mounting on a properly flat surface. Locate thermostat where it will be exposed to unrestricted circulation of air which represents the average temperature of the controlled space. Install thermostat in any normal human environment.

Caution: Do not locate the thermostat near sources of heat or cold, such as lamps, motors, sunlight, or concealed ducts or pipes. Avoid locations where excessive vibration, moisture, corrosive fumes or vapors are present. NEMA Type 1 covers are intended to provide a degree of protection against contact with the enclosed equipment.

MOUNTING

1. Pull all wires (use copper wire only).
2. Fasten mounting plate to switch box (Figure 2).
3. Make electrical connections to switch leads and thermostat terminals. (See Figure 4 for typical wiring diagram).
4. Hook thermostat on top of mounting plate and swing down into place.
5. Tighten thermostat mounting screw.

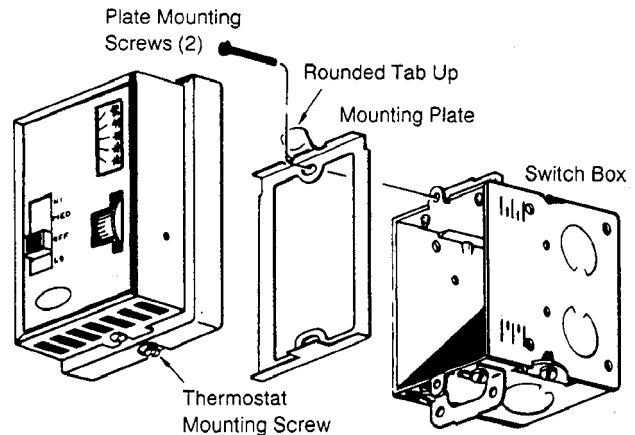

Figure-2 Thermostat Mounting.

CHECKOUT

1. With power on, check fan speed by placing switch in low, medium and high positions.
2. To observe action of controlled devices:
 - Place fan switch in low, medium or high position.
 - Turn the setpoint dial to temperature above ambient; thermostat will switch, closing the Brown (heating) contact.
 - Slowly turning the setpoint dial to a lower temperature setting will first break the Brown (heating) contact. The contact blade will be in a neutral position between the two contacts (not making a circuit to either contact). Turning the setpoint dial to a lower temperature setting will cause the thermostat to switch, closing the Red (Cooling) contact.

CALIBRATION

THERMOSTATS ARE CALIBRATED AT THE FACTORY AND DO NOT REQUIRE JOB SITE CALIBRATION.

Allow two days for systems and wall temperature to stabilize before considering recalibration as follows: (See Figure 3 for part identification).

1. Disconnect power to thermostat.
2. Turn the setpoint dial 2°F (1°C) above the actual room temperature, as read from an accurate thermometer.
3. Place fan switch in "off" position. Remove thermostat cover and insulator screw, swing insulator aside, and remove contact cover.

Note: Do not breathe on the thermostat or handle excessively as this will affect the accuracy of the final calibration.

4. If contact blade is made to the left Brown contact, use a 3/16" open end wrench TOOL-11 and turn calibration screw counterclockwise (looking at head of screw) until blade floats between contacts.

Note: Each complete turn of screw changes calibration approximately 20°F (11°C).

5. Now turn screw very slowly clockwise until blade just makes the left Brown contact. Thermostat is now properly calibrated.
6. If contact blade is originally made to the right Red contact or floating between contacts, turn calibration screw slowly clockwise until element just makes the left Brown contact. Thermostat is now properly calibrated.
7. With fan switch in "off" position, replace contact cover, insulator and thermostat cover.
8. Connect power to thermostats.
9. Turn setpoint dial to required temperature and place fan switch in desired position.

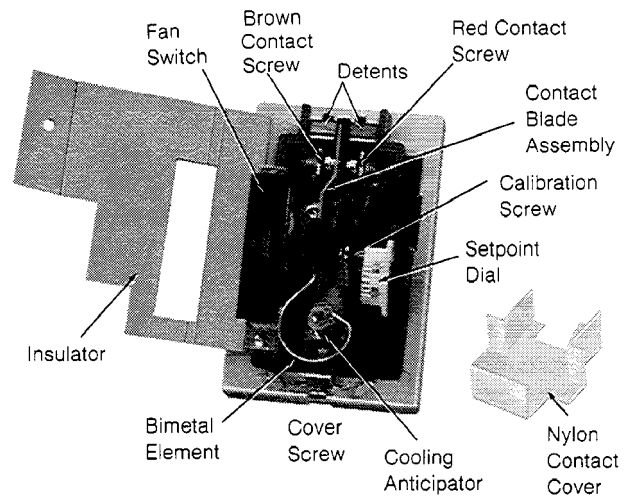

Figure-3 Part Identification.

MAINTENANCE

This is a quality product. Regular maintenance of the total system is recommended to assure sustained optimum performance. No routine servicing of this device is required if the system is properly maintained.

Open areas at bottom and around base of the thermostat should be kept clean and free from obstructions to allow proper flow of air. If switch contacts need cleaning, this may be done with a burnishing tool.

Note: Thermostat may require calibration after contact cleaning.

REPAIR

No field repair is possible. Replace thermostat with a functioning unit.

Note: Normally closed cooling valve required for proper system operation.

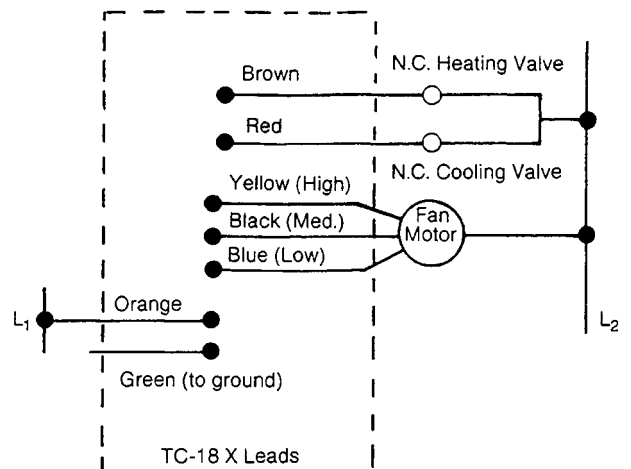

Figure-4 Typical Sequenced Heating & Cooling Anticipation (no changeover thermostat required).

Copyright 2006, TAC
All brand names, trademarks and registered
trademarks are the property of their respective
owners. Information contained within this
document is subject to change without notice.

TAC
1354 Clifford Avenue
P.O. Box 2940
Loves Park, IL 61132-2940

F-20044-2



www.tac.com

