

**Positive Positioner Kit
Installation Instructions**

Application

This kit contains an N800-0555 positive positioning relay, an N800-1501 feedback arm, and springs for 5 psi and 10 psi spans for the M556, M573, and M574 pneumatic damper actuators.

Installation

INSPECTION

Inspect the package for damage. If damaged, notify the appropriate carrier immediately. If undamaged, open the package and inspect the kit for any obvious damage. Return damaged products.

MOUNTING

The positioner is designed to mount on one of the housing screw posts of the M556, M573, or M574 pneumatic actuators.

1. Select the position required.
2. Remove the selected housing screw.
3. Slide the positioner over the screw post and securely reinsert the screw.
4. Unthread the clevis or ball joint from the actuator shaft.
5. Align the holes in the feedback arm (Figure-1) and the shaft fitting.
6. Insert the threaded end of the shaft fitting through the appropriate hole in the feedback arm, and rethread the fitting into the output shaft. Do not tighten securely.

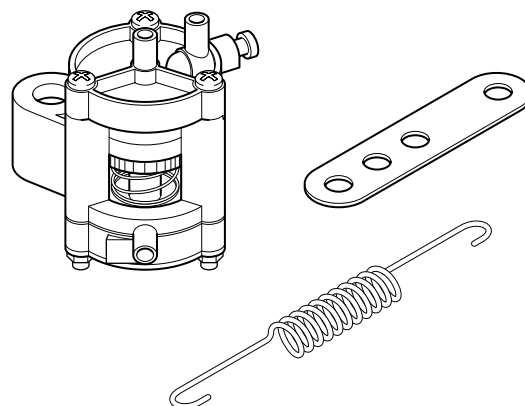

7. Remove the appropriate spring from the kit. (Refer to Table-1 for selections.) Hook one end of the spring onto the positioner (Figure-2) and the other end into the spring hole in the end of the feedback arm (Figure-1).
8. Align the feedback arm so that the spring is perpendicular to the positioner.
9. Tighten the shaft fitting securely to the output shaft.

PIPING

Refer to Figure-2. The positioner requires a signal connection to "S" and a main air connection to "M". The positioner output, located above the needle-valve, is connected to the actuator signal port. Fittings are provided for 1/4 in. O.D. plastic tubing.

Table-1 Spring Selection. The springs in the kit may be Type A, Type B, or a combination of the two types.

Actuator Type	For Span of	Spring Part Number	Type A		Type B	
			Length (inches)†		Length (inches)†	
			Overall	Coil	Overall	Coil
M556	5 psi	N800-2259	9	8	8-1/4	3-11/16
	10 psi	N800-2269	—	—	8-3/8	1-3/4
M573	5 psi	N800-2257	4-5/8	3-11/16	4-5/8	1-15/16
	10 psi	N800-2267	4-11/16	3-15/16	4-3/4	7/8
M574	5 psi	N800-2258	5-13/16	4-7/8	5-7/8	2-1/2
	10 psi	N800-2268	6-1/8	5-7/16	6-1/8	1-1/8

†Dimensions are approximate.

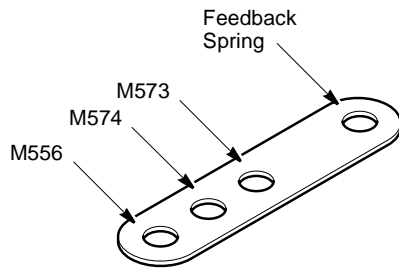

Figure-1 Feedback Arm.

Adjustments

SPAN

The signal pressure change required to produce full actuator stroke is determined by the feedback spring. Select the spring from Table-1.

START POINT

Refer to Figure-2. The signal pressure at which the actuator shaft begins to move is adjustable from 3 to 12 psig by rotating the recessed brass knurled dial in the center of the positioner.

The start point of the actuator may be adjusted by setting the signal pressure to the desired value and turning the recessed knurled wheel by hand until the actuator shaft begins to move. Turning the wheel outward toward the spring raises the start point.

ADJUSTABLE NEEDLE-VALVE

Refer to Figure-2. The needle-valve allows the adjustment of the rate of actuator movement. With this needle-valve, the speed of the M556, M573, and M574 actuators may be adjusted with a small blade screwdriver, if required, to:

Give the actuators the same relative rate of movement

This makes it possible, for example, to have outside, return, and relief dampers on an air handling unit move together, rather than at different rates. This is especially important at the following times:

- When large air handling units are started and stopped.
- When dampers are switched from “summer” to “winter” operation or the reverse.

Both of the above examples can cause large damper movements.

Adjust the actuators to move slowly so that a narrower controller throttling range can be used

This is important for the following:

- Controlling supply air static pressure with a vortex damper.
- Controlling mixed air temperature with outside, return, and relief dampers.
- Controlling space static pressure with one or more relief dampers.

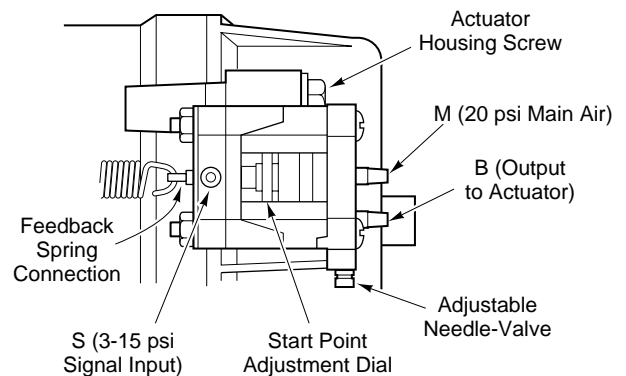

Figure-2 Positioner Adjustment and Port Connections.