

**TAC DuraDrive Series Non-spring Return  
Floating Actuators  
General Instructions**

## Application

TAC DuraDrive<sup>®</sup> Direct Coupled Actuators are designed to be used in both damper and valve control applications. The following general instructions are for damper applications, refer to the Applicable Literature table for valve literature.

The MF41-6343 is an over the shaft non-spring return actuator for use with floating three-wire output controllers.

## Features

- 300 lb.-in. (34 N-m) rated torque
- NEMA Type 4 housing (IEC IP56)
- Custom automatic current sensing motor control provides extended reliability and repeatable timing
- Direct coupled to the damper shaft with dual industrial hardened universal mounting clamps
- Floating actuator controlled by SPDT floating controllers, Triacs, or DDC controllers with 2 SPST (drive open, hold, drive closed) outputs
- Clockwise or counterclockwise rotation is determined by actuator mounting position
- Manual override for ease of installation and manual operation of damper
- Accurate 101° travel digitally controlled (with mechanical stop limits)
- Integral position indication scale
- Rugged die cast housing
- Oil immersed gear train provides continuous lubrication
- Rated for operating temperatures up to 140 °F (60 °C)
- Five year warranty
- MF41-6343 Actuators can be double-mounted (gang mounting) to accommodate high torque application requirements (2 to 4 actuators)

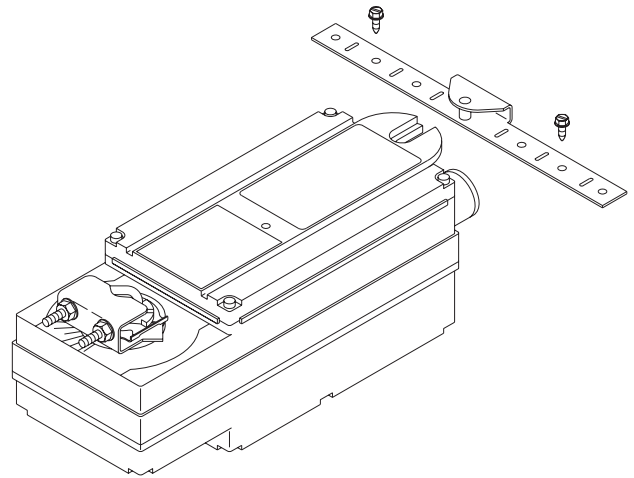

## Applicable Literature

F-Number	Description	Audience	Purpose
F-27160	Actuator/Linkage Assemblies for 2-1/2" to 6" globe Valves General Instructions	<ul style="list-style-type: none"> <li>- Sales Personnel</li> <li>- Application Engineers</li> <li>- Installers</li> <li>- Service Personnel</li> <li>- Start-up Technicians</li> </ul>	Describes the globe valve actuator/linkage assembly's features, specifications, and possible applications. Provides step-by-step mounting instructions.
F-27082	AV-607, AV-609 TAC DuraDrive Linkages for 2-1/2" to 6" Globe Valves General Instructions	<ul style="list-style-type: none"> <li>- Sales Personnel</li> <li>- Application Engineers</li> <li>- Installers</li> <li>- Service Personnel</li> <li>- Start-up Technicians</li> </ul>	Describes the globe valve actuator/linkage assembly's features, specifications, and possible applications. Provides step-by-step mounting instructions.
F-26646	MX41-6043, MX40-7XXX, MX41-6XXX Series TAC DuraDrive Actuator Selection Guide	<ul style="list-style-type: none"> <li>- Sales Personnel</li> <li>- Application Engineers</li> <li>- Installers</li> <li>- Service Personnel</li> <li>- Start-up Technicians</li> </ul>	Provides actuator specifications and part number cross referencing of phased out actuators with the new TAC direct-coupled actuators.
F-26752	VX-7000 & VX-9000 Series, MX41-6XXX, MX4X-7XXX Series, Linked Globe Valve Assemblies and Actuator/Linkage Assemblies with TAC DuraDrive Actuators Selection Guide	<ul style="list-style-type: none"> <li>- Sales Personnel</li> <li>- Application Engineers</li> <li>- Installers</li> <li>- Service Personnel</li> <li>- Start-up Technicians</li> </ul>	Provides features, specifications, mounting dimensions, and other criteria useful to the selection of linked globe valve assemblies and actuators/linkage assemblies with TAC DuraDrive actuators.
F-25097	AM-674 Weather Shield General Instructions	<ul style="list-style-type: none"> <li>- Sales Personnel</li> <li>- Application Engineers</li> <li>- Installers</li> <li>- Service Personnel</li> <li>- Start-up Technician</li> </ul>	Provides step-by-step mounting instructions.
F-25098	AM-676 Universal Shaft Extension General Instructions	<ul style="list-style-type: none"> <li>- Sales Personnel</li> <li>- Application Engineers</li> <li>- Installers</li> <li>- Service Personnel</li> <li>- Start-up Technician</li> </ul>	Provides step-by-step mounting instructions.
F-26898	AM-751 Standard Anti-rotation Bracket General Instructions	<ul style="list-style-type: none"> <li>- Sales Personnel</li> <li>- Application Engineers</li> <li>- Installers</li> <li>- Service Personnel</li> <li>- Start-up Technician</li> </ul>	Provides step-by-step mounting instructions.
	AM-752 Optional Anti-rotation Bracket General Instructions		
	AM-753 Optional Universal Mounting Clamps General Instructions		
	AM-754 Standard Universal Mounting Clamps General Instructions		
F-26899	AM-756 Metric Conduit Adaptor General Instructions	<ul style="list-style-type: none"> <li>- Sales Personnel</li> <li>- Application Engineers</li> <li>- Installers</li> <li>- Service Personnel</li> <li>- Start-up Technician</li> </ul>	Provides step-by-step mounting instructions.
F-26080	EN-205 Water System Guidelines	<ul style="list-style-type: none"> <li>- Application Engineers</li> <li>- Installers</li> <li>- Service Personnel</li> <li>- Start-up Technicians</li> </ul>	Describes TAC approved water treatment practices.
F-13755	CA-28 Control Valve Sizing	<ul style="list-style-type: none"> <li>- Application Engineers</li> <li>- Installers</li> <li>- Service Personnel</li> <li>- Start-up Technicians</li> </ul>	Provides charts, equations, and diagrams to assist in the configuration of valve system applications. TOOL-150, valve sizing slide rule may be purchased separately.
F-11080	Valve Selection Chart Water		
F-11366	Valve Selection Chart Steam (two-way valves only)		

# SPECIFICATIONS

## Inputs

**Control Signal:** SPDT floating control input; Triacs (500 mA rated) or 2 SPST contacts. See Figure-1 through Figure-4.

**Power Input:** See Table-1. All 24 Vac and 22-30 Vdc circuits are Class 2.

### Connections:

**Ground,** 36 inch (91 cm) long, 18 AWG green/yellow pigtail lead.

**Power and Control,** 36 inch (91 cm) long, 22 AWG color coded appliance cable leads.

## Outputs

### Electrical:

**Stroke,** Mechanically limited to  $101^\circ \pm 1^\circ$ .

**Torque** See Table-1.

**Duty Cycle** 100%.

**Timing** See Table-1.

### Mechanical:

**Manual Override,** Allows manual positioning.

#### Anti-Rotation Bracket,

**Standard** 9" long x 13/16" wide (229 x 21 mm), AM-751 is included with the actuator.

**Optional** Order AM-752 (4" long x 1-11/16" wide) for mounting the actuator in narrow spaces.

**Universal Mounting Clamps,** Two clamps are required for all mounting configurations.

**Standard** AM-754, 3/8" to 1/2" (10 to 13 mm) round and square shaft mounting clamps are included with the actuator.

**Optional** Order AM-753 for 5/8" (16 mm) square and 3/4" to 1" (19 to 25 mm) round damper shafts, two per package.

#### Minimum Damper Shaft Length,

**Standard** Damper shaft must be at least 4-5/8" (117 mm) long for standard mounting.

**Optional** Shorter than standard length shafts require the AM-676 shaft extension. Order separately.

**Position Indicator,** Scale numbered from 0 to 95°, provided for position indication.

**Nominal Damper Area,** Actuator sizing should be done in accordance with damper manufacturer's specifications.

**Direction of Rotation,** Clockwise or counterclockwise rotation determined by actuator mounting. The zero (0) position on the position indicator is the normal position.

## Environment

### Ambient Temperature Limits:

**Shipping & Storage,** -40 to 160 °F (-40 to 71 °C).

**Operating,** -25 to 140 °F (-32 to 60 °C).

**Humidity:** 5 to 95% RH, non-condensing.

**Location:** NEMA Type 1. NEMA Type 4 (IEC IP56) with customer supplied water tight conduit connectors.

## Agency Listings

**UL 873:** Underwriters Laboratories Inc. listed (File # E9429 Category Temperature-Indicating and Regulating Equipment).

**CUL:** UL Listed for use in Canada by Underwriters Laboratories. Canadian Standards C22.2 No. 24-93.

**European Community:** EMC Directive (2004/108/EC). Low Voltage Directive (72/23/EEC).

**Australia:** This product meets requirements to bear the C-Tick Mark according to the terms specified by the Communications Authority under the Radiocommunications Act 1992.

**Table-1 Model Chart.**

Part Number	Actuator Power Input						Approximate 101° Rotation Timing in Seconds @ 70 °F (21 °C) for Rated Torque	Output Torque Rating lb.-in. (N-m)	
	Voltage	Hz		Running VA	Watts			Minimum	Maximum Stall
		50	60		Running	Holding			
MF41-6343	24 Vac ± 20%	50	60	5.7	3.9	2.8	162	300 (34)	650 (73.7)
	22-30 Vdc			4.1	4.1	3.0			

## ACCESSORIES

AM-620	Remote mount single/dual damper actuator kit
AM-621	Round damper shaft extension kit (1/2" ID x 1" OD) for dual actuator mounting
AM-751	Standard Anti-rotation Bracket, 9" long x 13/16" wide (229 x 21 mm), included with actuator
AM-752	Optional Anti-rotation Bracket, 4" long x 1-11/6" wide (102 x 43 mm), for narrow spaces
AM-753	Optional Universal Mounting Clamps, for 5/8" (16 mm) square shaft, 3/4" to 1" (19 to 25 mm) round shafts (two per package)
AM-754	Standard Universal Mounting Clamps, for 3/8" to 1/2" (10 to 13 mm) round and square shafts, two included with actuator
AM-755	Manual Override Crank
AM-756	Metric Conduit Adaptor, M20 x 1.5 to 1/2" NPT (two per package)
AV-607	Dual mount rack and pinion valve linkage kit for 2-1/2" through 4" VB-8xxx and VB-9xxx series valve bodies
AV-609	Dual mount rack and pinion valve linkage kit for 5" and 6" VB-8xxx and VB-9xxx series valve bodies
X-5521	1/2" Pipe Plug, included with actuator

## TYPICAL APPLICATIONS (wiring diagrams)

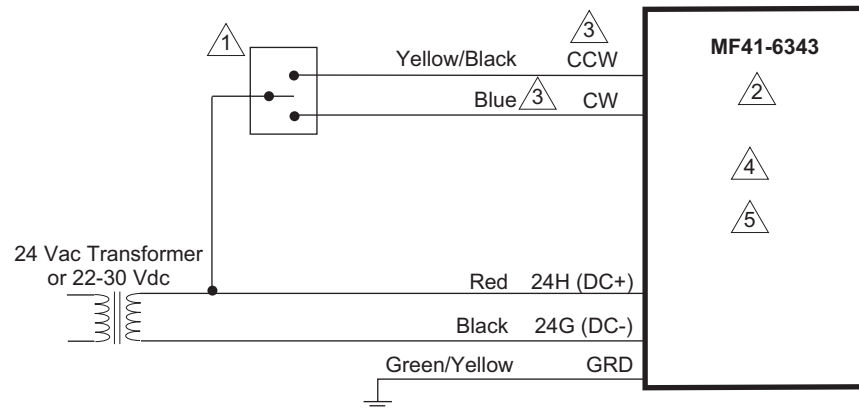

- 1 SPDT Floating or Switch/Controller or 2 SPST.
- 2 Unused conduit port must remain plugged with a water tight pipe plug as shipped from factory to maintain NEMA Type 4 or IP56 rating.
- 3 As viewed from "L" side
- 4 Color coding of wiring on older models (MF41-6343-0-0-0) manufactured prior to December, 2007, differs from current models. See Table-4 on page 13. Consult label on product to confirm wiring codes.
- 5 Keep CCW and CW drive signal wiring less than 30 meters length to meet CE requirements.

Figure-1 Typical SPDT Controller Wiring Diagram.

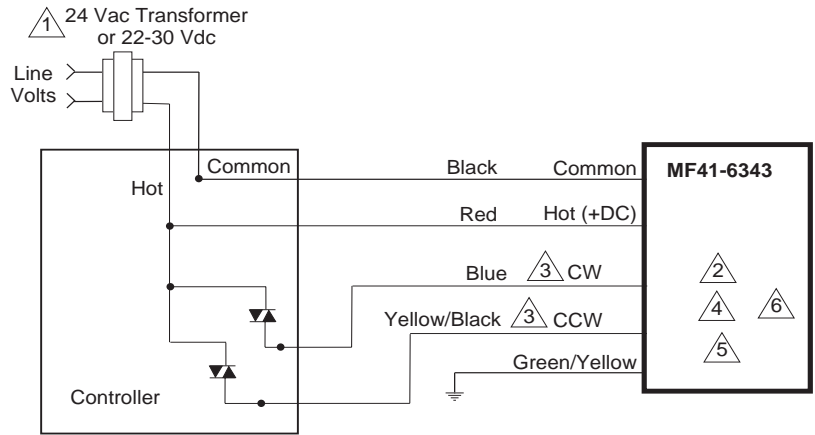

- 1 Provide overload protection and disconnect as required.
- 2 If the controller uses a full-wave power supply and does not provide isolated outputs, a separate transformer is required.
- 3 As viewed from "L" side.
- 4 Unused conduit port must remain plugged with a water tight pipe plug as shipped from factory to maintain NEMA Type 4 or IP56 rating.
- 5 Color coding of wiring on older models (MF41-6343-0-0-0) manufactured prior to December, 2007, differs from current models. See Table-4 on page 13. Consult label on product to confirm wiring codes.
- 6 Keep CCW and CW drive signal wiring less than 30 meters length to meet CE requirements

Figure-2 Triac Source.

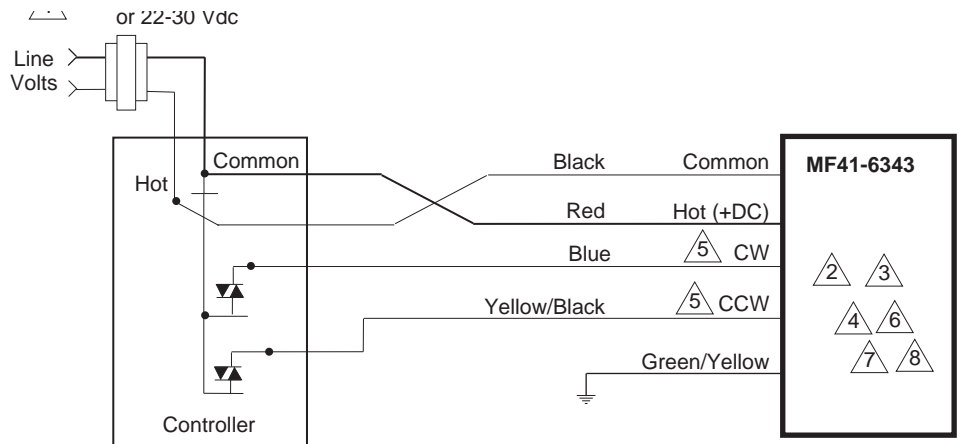

- 1 Provide overload protection and disconnect as required.
- 2 Actuators may be wired in parallel. All actuator black wires are connected to the transformer common and all red wires are connected to the hot lead. Power consumption must be observed.
- 3 The Common connection from the actuator must be connected to the Hot connection of the controller. The actuator Hot must be connected to the controller Common.
- 4 If the controller uses a full-wave power supply and does not provide isolated outputs, a separate transformer is required.
- 5 As viewed from "L" Side
- 6 Unused conduit port must remain plugged with a water tight pipe plug as shipped from factory to maintain NEMA Type 4 or IP56 rating.
- 7 Color coding of wiring on older models (MF41-6343-0-0-0) manufactured prior to December, 2007, differs from current models. See Table-4 on page 13. Consult label on product to confirm wiring codes.
- 8 Keep CCW and CW drive signal wiring less than 30 meters length to meet CE requirements

Figure-3 Triac Sink.

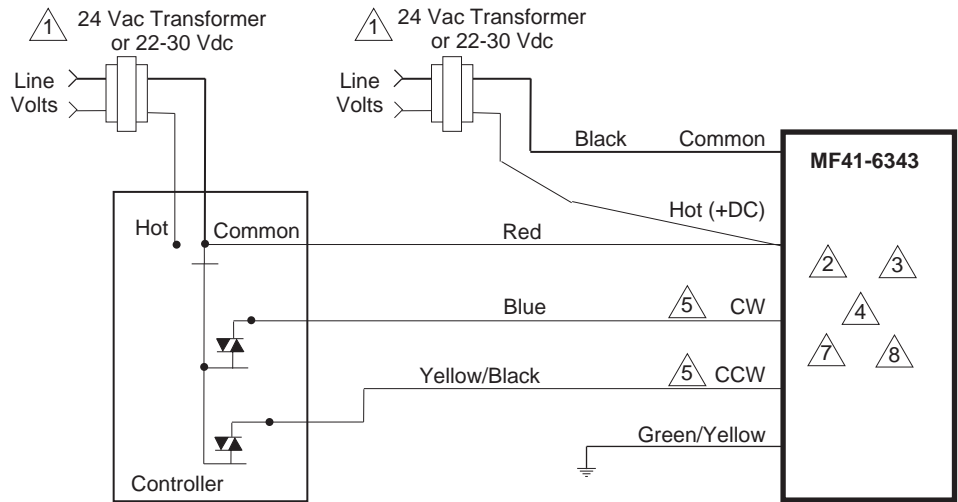

- 1 Provide overload protection and disconnect as required.
- 2 Actuators may be wired in parallel. All actuator black wires are connected to the transformer common and all red wires are connected to the hot lead. Power consumption must be observed.
- 3 The actuator Hot must be connected to the controller Common.
- 4 If the controller uses a full-wave power supply and does not provide isolated outputs, a separate transformer is required.
- 5 As viewed from "L" side.
- 6 Unused conduit port must remain plugged with a water tight pipe plug as shipped from factory to maintain NEMA Type 4 or IP56 rating.
- 7 Color coding of wiring on older models (MF41-6343-0-0-0) manufactured prior to December, 2007, differs from current models. See Table-4 on page 13. Consult label on product to confirm wiring codes.
- 8 Keep CCW and CW drive signal wiring less than 30 meters length to meet CE requirements

Figure-4

# INSTALLATION

## Inspection

Inspect the package for damage. If damaged, notify the appropriate carrier immediately. If undamaged, open the package and inspect the device for obvious damage. Return damaged products.

## Requirements

- Job wiring diagrams
- Tools (not provided)
  - Socket wrench 1/2 inch, used for universal mounting clamp nuts
  - Open-end wrench 10 mm, used for installing AM-676 universal shaft extension
  - Slotted screwdriver, used for installing anti-rotation brackets
  - Allen wrench 3/16", used for manual override
- Appropriate accessories
  - Water tight 1/2 inch conduit seals T&B #5332 (straight), T&B #5352 (90°), or equivalent.
  - Water tight 1/2 inch flexible conduit (e.g. Anaconda: Sealtight) or 20 mm flexible water tight conduit when using AM-756 metric conduit adapter with appropriate metric water tight seals
  - Water tight 1/2" flexible conduit (Anaconda: Sealtight) or 20 mm flexible water tight conduit when using AM-756 metric conduit adapter
  - Two #8 1/2" (13 mm) sheet metal screws for mounting (optional)
- Training: Installer must be a qualified, experienced technician

## Precautions

### General

---



**Warning:** Electrical shock hazard! Contact with live circuits can result in severe injury or death.

- Disconnect the power supply (line power) at the breaker or fuse before and during installation to prevent electric shock and equipment damage.
- Make all connections in accordance with the wiring diagram and in accordance with national and local electrical codes. *Use copper conductors only.*

Failure to observe these warnings can result in severe injury or death and can damage the equipment.

---



**Caution:** Avoid electrical noise interference and follow ambient temperature ratings.

- Do not install near large contactors, electrical machinery, or welding equipment.
- Avoid locations where excessive moisture, corrosive fumes, vibration, or explosive vapors are present.
- DuraDrive Actuators are intended for indoor use only. Locate where ambient temperatures do not exceed 140 °F (60 °C) or fall below -25 °F (-32 °C) and relative humidity does not exceed 95% or fall below 5%, non-condensing.

Failure to observe these precautions can damage the equipment.

---

### Federal Communications Commission (FCC)

---

**Note:** This equipment has been tested and found to comply with the limits for a Class B digital device, pursuant to Part 15 of the FCC Rules. These limits are designed to provide reasonable protection against harmful interference in residential installations. This equipment generates, uses, and can radiate radio frequency energy and may cause harmful interference if not installed and used in accordance with the instructions. Even when instructions are followed, there is no guarantee that interference will not occur in a particular installation. If this equipment causes harmful interference to radio or television reception—which can be determined by turning the equipment off and on—the user is encouraged to try to correct the interference by one or more of the following measures:

- Reorient or relocate the receiving antenna.
  - Increase the separation between the equipment and receiver.
  - Connect the equipment to an outlet on a circuit different from that to which the receiver is connected.
  - Consult the dealer or an experienced radio/television technician for help.
-

## Canadian Department of Communications (DOC)

---

**Note:** This class B digital apparatus meets all requirements of the Canadian Interference-Causing Equipment Regulations.

Cet appareil numérique de la classe B respecte toutes les exigences du Règlement sur le matériel brouilleur du Canada.

---

## European Standard EN 55022

---



**Caution:** This is a class B (European Classification) product. In a domestic environment this product may cause radio interference in which case the user may be required to take adequate measures.

Failure to observe this precaution can damage the equipment.

---

## Location



**Caution:** Prevent water damage.

- To maintain NEMA Type 4 rating, use water tight 1/2" flexible conduit only, with 1/2" conduit connector of the water tight type, T&B #5332 (straight), T&B #5352 (90°), or equivalent.
- For metric conduit applications using AM-756 conduit adapters, use the appropriate metric water tight seals to maintain compliance with IP56 or NEMA Type 4 rating.
- Use a water tight 1/2" pipe plug in any unused actuator conduit ports and seal with water tight tape to stay in compliance with NEMA Type 4 or IP56 rating. Use TAC part number X-5521, Grinnell #8700159257 (black), Grinnell #8700159851 (galvanized), or equivalent. Actuators with unused conduit ports are shipped with the unused port plugged.

Failure to observe these precautions can damage the equipment.

---

## Mounting

Mount the TAC DuraDrive Actuator directly on the damper shaft in locations that clear the maximum dimensions of the actuator case and allow the actuator to be mounted flush to the surface of the terminal box and perpendicular to the damper shaft.

---

**Note:** Some terminal boxes have sheet metal screw heads or other protrusions near the damper shaft. In these cases, a spacer or shim may be added under the mounting tab of the actuator to make the actuator perpendicular to the shaft.

---

## Damper Actuator Sizing

Correct sizing of the actuator is necessary for proper control of dampers. The area of damper that can be controlled by a given actuator is dependent upon the quality of the damper, the pressure drop across the damper in the closed position, and the velocity of the air flow through the damper. To obtain actual damper torque requirements, contact the damper manufacturer.

## Damper Shaft Sizing

Use the "Long Damper Shaft" mounting instructions if the damper shaft is at least 4-5/8" (117 mm) long.

Use the "Short Damper Shaft" mounting instructions if the damper shaft is shorter than 4-5/8" or the area around the damper shaft is too narrow to allow standard mounting, as described in the "Long Damper Shaft" mounting section. See Figure-5 for minimum shaft length.

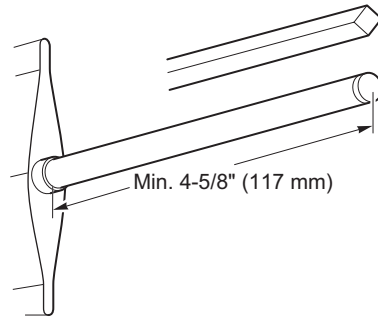

Figure-5 Long Damper Shaft Dimensions.



**Caution:** The MF41-6343 actuator is not designed to be used on aluminum damper shafts, solid steel shafts smaller than 1/2" diameter round or 1/2" square, or hollow steel shafts smaller than 3/4" round. The actuator can produce up to 650 in-lbs (73.7 N-m) maximum stall torque, which could result in the actuator snapping off an aluminum damper shaft or an improperly sized steel damper shaft. Refer to Table-2 for nominal damper shaft sizes. Failure to observe this precaution can damage the equipment.

**Table-2 Steel Damper Shaft Specifications.**

Damper Shaft Shape	Damper Shaft Type	O.D. (Nominal) <sup>a</sup>	I.D. (Maximum)
Round	Solid bar	1/2" to 1"	0
	Hollow tubing	3/4"	3/8"
		13/16"	11/16"
		27/32"	5/8"
		7/8"	13/16"
		15/16"	13/16"
		1"	29/32"
Square	Solid bar	1/2" to 5/8"	0

<sup>a</sup> Damper shaft sizes over 1/2" (13 mm) O.D. require AM-753 universal mounting clamps.

### Mounting the Actuator for Clockwise or Counterclockwise Dampers

The zero (0) position on the position indicator is the normal or spring return position. When the actuator is mounted with the "R" side facing the installer and the control signal increases the actuator will rotate in the counterclockwise direction. When the actuator is mounted with the "L" side facing the installer and the control signal increases the actuator will rotate in the clockwise direction.

### Long Damper Shafts

1. Move the damper to the closed position. Verify the controller action is set to match the damper application. See TYPICAL APPLICATIONS (wiring diagrams).
  - For normally closed damper: when damper is closed, actuator position indicator should be at 0°. When damper is open, actuator position indicator should be at 90°.
  - For normally opened damper: when damper is open, actuator position indicator should be at 0°. When damper is closed, actuator position indicator should be at 90°.

**Note:** The actuator comes equipped with two AM-754 universal mounting clamps. For damper shafts larger than 1/2" (13 mm) in diameter, the AM-753 universal mounting clamps are required (order separately). The AM-753 clamps accommodate round shaft sizes ranging from 3/4" to 1" (19 to 25 mm) or 5/8" (16 mm) square shafts.

2. Slide the actuator over the shaft and into its desired final mounting position.
  - If the damper shaft rotates clockwise to the closed position, mount the actuator with the side marked "R" facing the installer. See Figure-6.
  - If the damper shaft rotates counterclockwise to the closed position, mount the actuator with the side marked "L" facing the installer. See Figure-7.

3. Hand tighten the nuts on both of the actuator's universal mounting clamps.
4. Align the actuator at 90° (perpendicular) to the damper shaft. See Figure-8.
5. Slide the anti-rotation bracket pin into the mounting slot on the actuator and drill mounting holes. See Figure-8. For narrow spaces, the AM-752 anti-rotation bracket is recommended (order separately).
6. Attach one side of the anti-rotation bracket to the mounting surface with one of the screws provided. Leave the screw loose so that the bracket can be rotated.
7. Pivot the anti-rotation bracket away from the actuator. See Figure-6.
8. Loosen the universal mounting clamps, making sure not to move the damper shaft. Rotate the actuator approximately 5° in the direction which would open the damper. See Figure-6.
9. Tighten all of the universal mounting clamp nuts with a 1/2" socket wrench. Apply 4 to 6 ft. -lbs (5 to 8 N-m) of torque.
10. Manually rotate the actuator toward the full-closed position to apply pressure to the damper seals. See Figure-6.
11. Pivot the anti-rotation bracket into place and secure the other side of the bracket onto the mounting surface using the other screw provided with the actuator. See Figure-6.
12. Verify that the damper is in its full-closed position and actuator at 90° (perpendicular) to the damper shaft. See Figure-6.

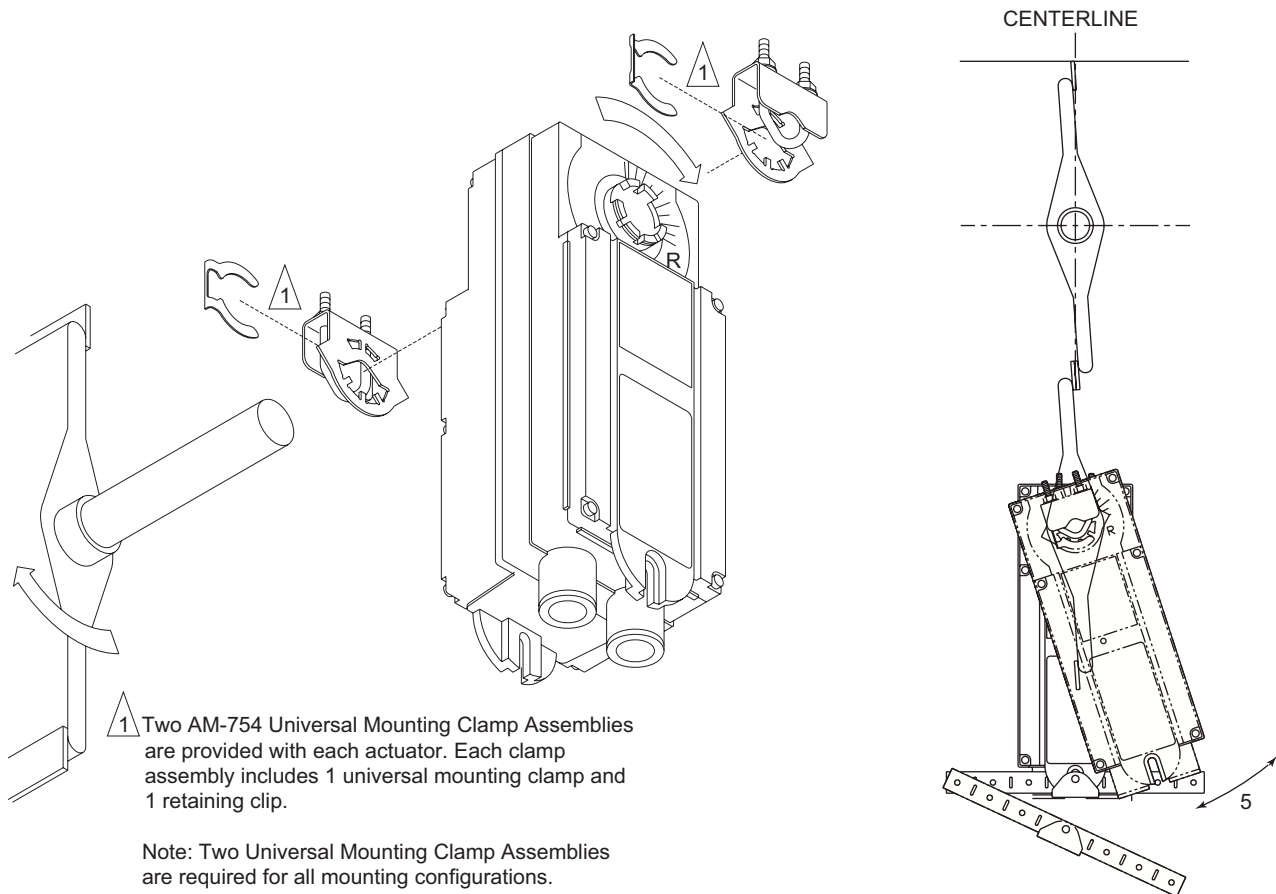

Figure-6 Long Damper Shaft Installation and Actuator Parts Identification.

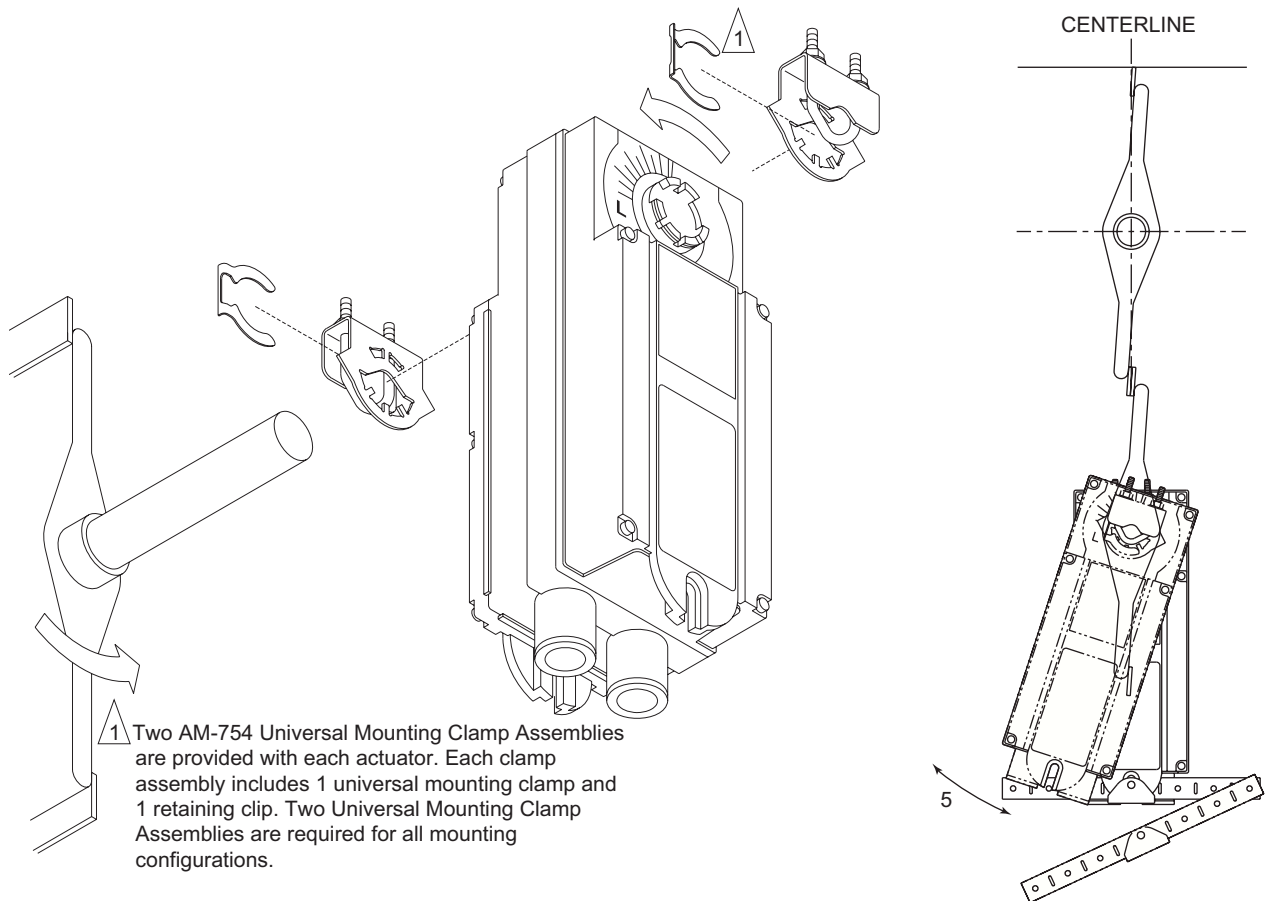

Figure-7 Long Damper Shaft Installation and Actuator Parts Identification.

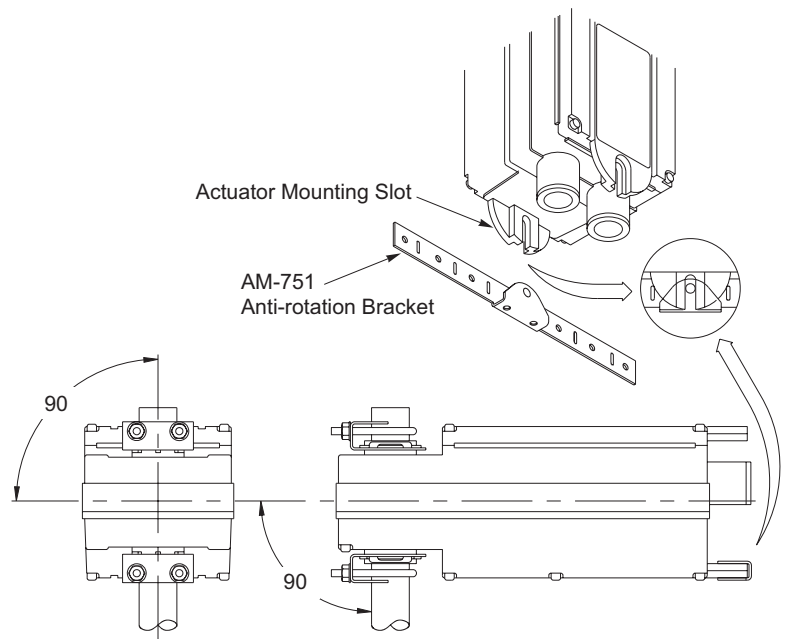

Figure-8 Mounting Anti-rotation Bracket to Actuator.

## Short Damper Shafts

See Figure-9 for installation of actuator using the AM-676 Universal Shaft Extension. Installation requires AM-676 Universal Shaft Extension and AM-753 Universal Mounting Clamps for 3/4" to 1" (19 to 25 mm) shafts, these items must be ordered separately.

1. Loosen the V-clamp nuts on the AM-676 universal shaft extension.
2. Fit the universal shaft extension fully onto the damper shaft. Tighten the universal shaft extension V-clamp nuts with a 10 mm open-end wrench. Apply 4 to 6 ft-lbs (5 to 8 N-m) of torque.
3. Move the damper to the closed position. Verify the controller action is set to match the damper application.
  - For normally closed damper: when damper is closed, actuator position indicator should be at 0°. When damper is open, actuator position indicator should be at 90°.
  - For normally opened damper: when damper is open, actuator position indicator should be at 0°. When damper is closed, actuator position indicator should be at 90°.
4. Remove the mounting clamps from the actuator and replace them with the AM-753 universal mounting clamps.
5. Loosen the nuts on both of the AM-753 universal mounting clamps on the damper actuator.
  - If the damper shaft rotates clockwise to the closed position, mount the actuator with the side marked "R" facing the installer. See Figure-6.
  - If the damper shaft rotates counterclockwise to the closed position, mount the actuator with the side marked "L" facing the installer. See Figure-7.
6. Assemble the damper actuator onto the universal shaft extension, allowing the extension to slide through the actuator's universal mounting clamps. Make sure the actuator is 90° (perpendicular) to the damper shaft. Then, hand tighten the nuts on both of the actuator's universal mounting clamps. See Figure-9

---

**Note:** If the universal shaft extension protrudes excessively above the damper actuator's top universal mounting clamp:

- remove the damper actuator from the universal shaft extension,
- remove the extension from the damper shaft,
- shorten the universal shaft extension by cutting it to the desired length,
- then proceed to follow mounting instructions.

- 
7. Slide the anti-rotation bracket pin into the mounting slot on the actuator. See Figure-8. For narrow spaces, the AM-752 anti-rotation bracket is recommended (order separately).
  8. Position the actuator and bracket in the desired final mounting position on the mounting surface and drill mounting holes. See Figure-9.
  9. Attach one side of the anti-rotation bracket to the mounting surface with one of the screws provided. Leave the screw loose so that the bracket can be rotated. See Figure-6.
  10. Pivot the anti-rotation bracket away from the actuator. See Figure-6.
  11. Loosen the universal mounting clamps, making sure not to move the damper shaft. Rotate the actuator approximately 5° in the direction which would open the damper. See Figure-6.
  12. Tighten all of the universal mounting clamp nuts with a 1/2" socket wrench. Apply 4 to 6 ft-lbs (5 to 8 N-m) of torque.
  13. Manually rotate the actuator toward the full-closed position to apply pressure to the damper seals. See Figure-6.
  14. Pivot the anti-rotation bracket into place and secure the other side of the bracket onto the mounting surface using the other screw provided with the actuator. See Figure-6.
  15. Verify that the damper is in its full-closed position and actuator at 90° (perpendicular) to the damper shaft. See Figure-6.

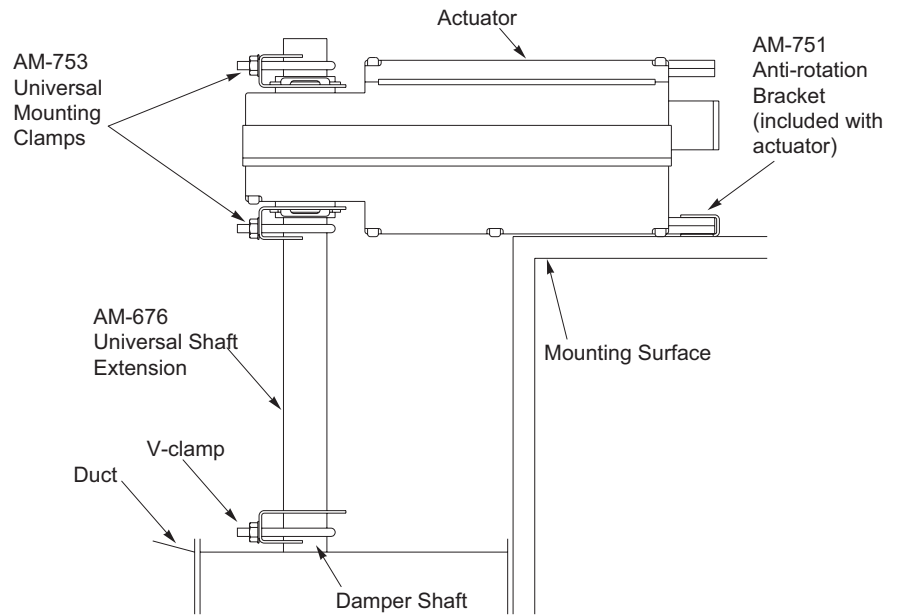

Figure-9 Installation of Universal Shaft Extension.

## Wiring Requirements

### Control and Power Leads

Remove blue plastic thread protectors before installing conduit fittings. See Figure-1 thru Figure 4 for typical wiring applications and Table-3 for maximum wire lengths.



**Caution:** This product contains a half-wave rectifier power supply and must not be powered by transformers used to power other devices utilizing non-isolated full-wave rectifier power supplies. Refer to *EN-206 Guidelines for Powering Multiple Full-Wave and Half-Wave Rectifier Devices from a Common Transformer*, F-26363, for further information. Failure to observe this precaution can damage the equipment.

**Note:** Class 2 control and power lead wiring must be routed separately from line voltage wiring and any other non-class 2 circuits.

Table-3 Control and Power Wiring Data.

Actuator Voltage	Part Number	Maximum Wire Run in ft. (m) (5% Voltage Drop)		
		14 AWG	16 AWG	18 AWG
24 Vac 22-30 Vdc	MF41-6343	1575 (480)	991 (302)	623 (190)

Table-4 Wire Color Codes for Models Manufactured before December, 2007.

Part Number	Power Voltage	L1	L2	Ground	24 H	24 G	Drive CW	Drive CCW	Common
MF41-6343-0-0-0 Old Design	24 Vac	N/A	N/A	Green/Yellow	Black	Black/Blue	White	Red	Black

N/A: Not Applicable

## ADJUSTMENTS

### Manual Override



---

**Caution:** Avoid physical damage to the actuator.

- Only use Manual Override when the actuator drive motor is not powered.
- Engaging the manual override when the actuator is powered will cause damage to the gears.
- Using power tools to adjust the override will cause damage to the gears.

Failure to observe these precautions can damage the equipment.

---

**Note:** Avoid manually repositioning the actuator beyond its adjustable travel limit setting.

---

The MF41-6343 actuator can be manually positioned to ease installation or for emergency positioning. See Figure-10.

1. Insert the 3/16" allen wrench into the hexagon hole located on the label side of the actuator. An illustration, located on the label, shows the location.
2. To engage manual override press and hold inward on the wrench while turning it in the direction shown on the label. It will take approximately 124 revolutions to rotate the full 101° of rotation.
3. Manual override is automatically disengaged by applying power to the drive open or drive closed, see Figure-1 through Figure-4. The actuator automatically disengages the override function and goes to the controller's desired position.

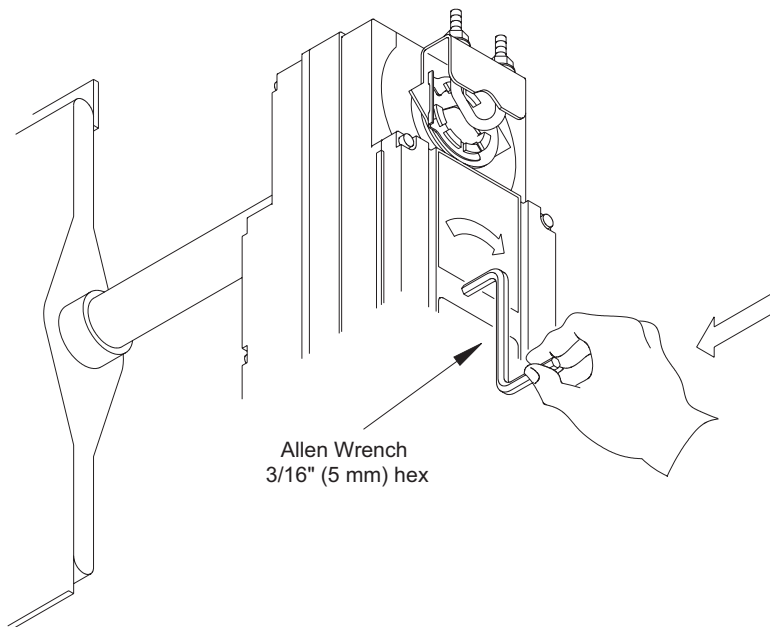

Figure-10 Manual Override Positioning.

## CHECKOUT

After the entire system has been installed and the actuator has been powered up, the following check can be made for proper system operation. Check for correct operation of the damper while actuator is being stroked.

---

**Note:** To check out a normally opened actuator the procedure is the same as below, except the initial position is open and closed when powered.

---

### Check Stroke

1. Remove power from actuator.
2. Insert the 3/16" allen wrench into the hexagon hole located on the label side of the actuator. An illustration, located on the label, shows the location.
3. Cycle the actuator its full 101° stroke (open/close) and verify that the damper travels through its complete range. To engage manual override press and hold inward on the wrench while turning it in the direction shown on the label.

### Operational Check

This procedure is for checking out an actuator that is typically mounted unpowered. It is possible to mount the actuator with power applied for special applications.

1. Apply power to the actuator and control system.
2. Set the switch/controller to cause the actuator to drive open (usually, Blue wire to 24H).
3. Check to see that the actuator travels to the full-open position.
4. Set the switch/controller to cause the actuator to drive closed (usually, Yellow/Black wire to 24H).
5. Check to see that the actuator travels to the fully closed position.

---

**Note:** If anticipated damper operation does not occur, verify the Long Damper Shaft or Short Damper Shaft mounting procedures. Also verify that the controller has the proper action (direct or reverse) to match the damper's required operation.

---

## THEORY OF OPERATION

The actuator is, by means of dual mounting clamps, directly mounted onto the damper shaft. The anti-rotation bracket supplied with the actuator will prevent lateral movement of the actuator. The damper actuator is not provided with and does not require any limiting switches, but is electronically protected against overloading.

The angle of rotation is mechanically limited to 101° ±1°. When reaching the damper or actuator end position, the motor stops automatically. The gears can be manually positioned when power is not available to the actuator. Insert allen wrench into a recessed hexagon socket on the actuator cover and push inward while turning. The position of the actuator is indicated by means of the scale reading 0 to 95°.

## MAINTENANCE

Regular maintenance of the total system is recommended to assure sustained optimum performance. The MF41-6343 actuator is maintenance free.

## FIELD REPAIR

None. Replace with functional actuator.

## DIMENSIONAL DATA

Figure-11 dimensions are in inches (mm).

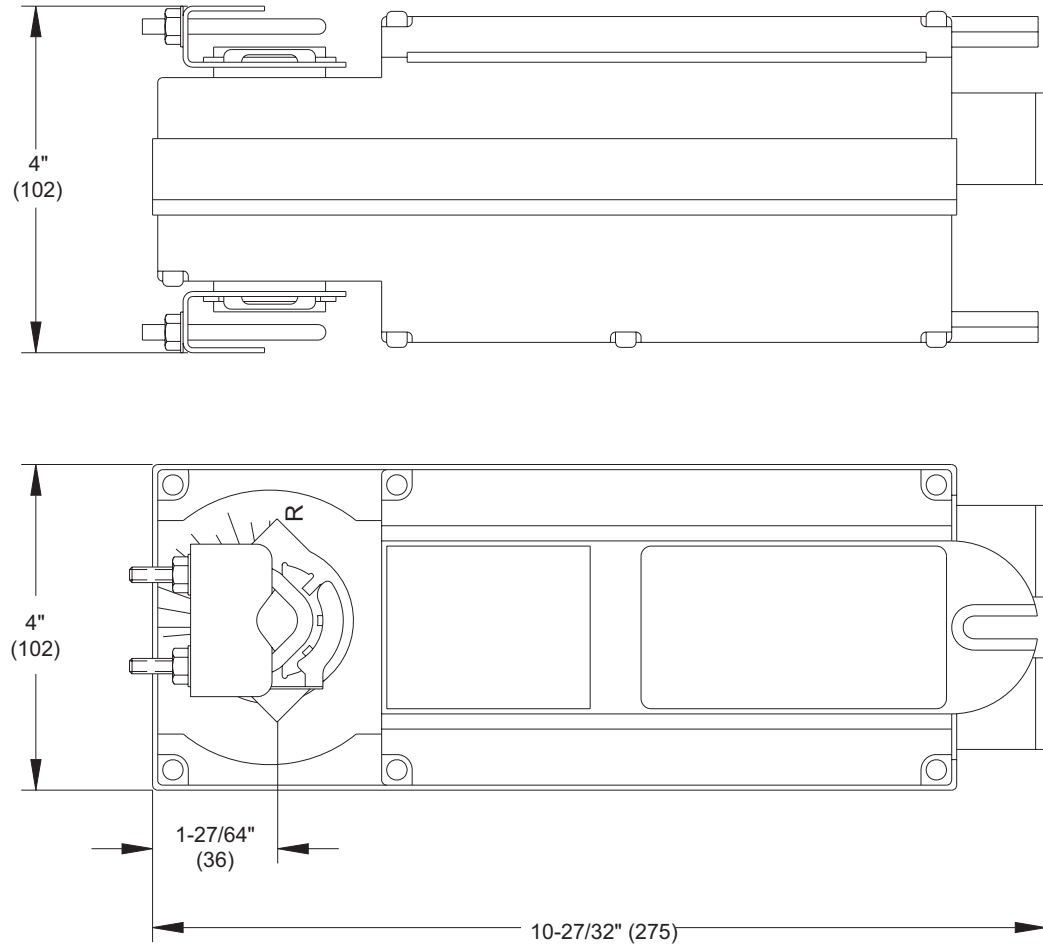

Figure-11 MF41-6343 Damper Actuator.