

VBB/VBS Series Ball Valves with Two-Position Actuators

Installation

Inspection

Inspect the package for damage. If package is damaged, notify the appropriate carrier immediately. If undamaged, open the package and inspect the device for obvious damage. Return damaged products.

Requirements

Tools (not provided)

- Wrench 1 to 1-5/8"
- Pipe wrench according to pipe size
- Volt-ohm multimeter
- Phillips Head screwdriver

Training— Installer must be a qualified, experienced technician

Other accessories as appropriate.

Warning Electrical shock hazard! Disconnect power before installation to prevent electrical shock or equipment damage. More than one disconnect switch may be required to de-energize the device. Make all connections in accordance with the electrical wiring diagram and in accordance with national and local electrical codes. Use copper conductors only. All conductors shall be provided with insulation rated for the highest voltage motor and end switch circuits.



Caution Avoid locations where excessive moisture, corrosive fumes, explosive vapors, or vibration are present. Avoid electrical noise interference. Do not install near large conductors, electrical machinery, or welding equipment. When making lead connections within the actuator, use caution not to put leads or connectors below the motor.



Piping These valves must be piped according to the flow diagram below. Two-Way valve flow should go A to AB. Three-way valves should only be applied as mixing valves (see diagram).

Caution Use in systems which have substantial make-up water (open systems) is not recommended. Follow proper water treatment practices and system procedures. Refer to document EN-205, F-26080 Water and Steam System Guidelines.

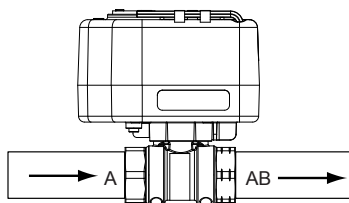
Two-Way Valve: Flow A to AB

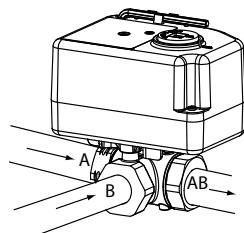

Three-Way Valve: Mixing Only A and/or B to AB.

Mounting

The valves can be mounted in horizontal or vertical piping. When installed in horizontal piping, the actuator must be above the valve body. It can be tilted left or right but it must not be tilted below 90° from vertical.

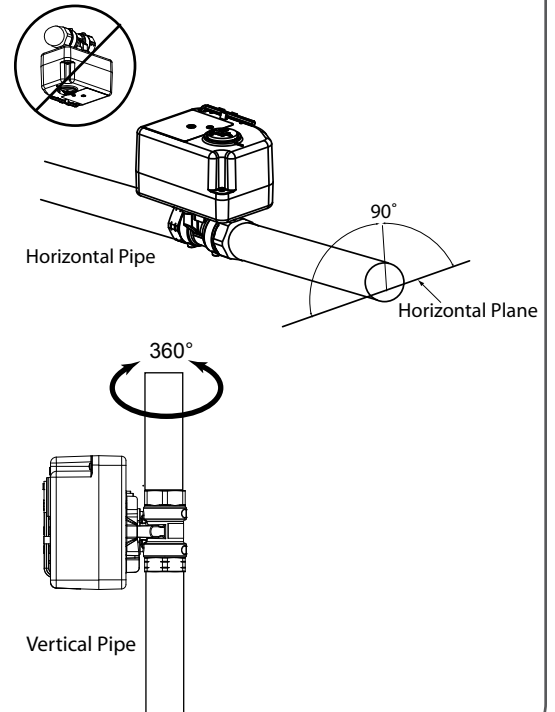

Installation Notes

- Make certain there is no overhead water source that may drip onto valve actuator.
- In normal service, some condensation may occur on or around the valve. A drip pan may be necessary or the valve body may be insulated.
- Do not cover the actuator or obstruct the manual operator lever.
- Reference product label and Product Datasheet F-27395 for additional product specifications.

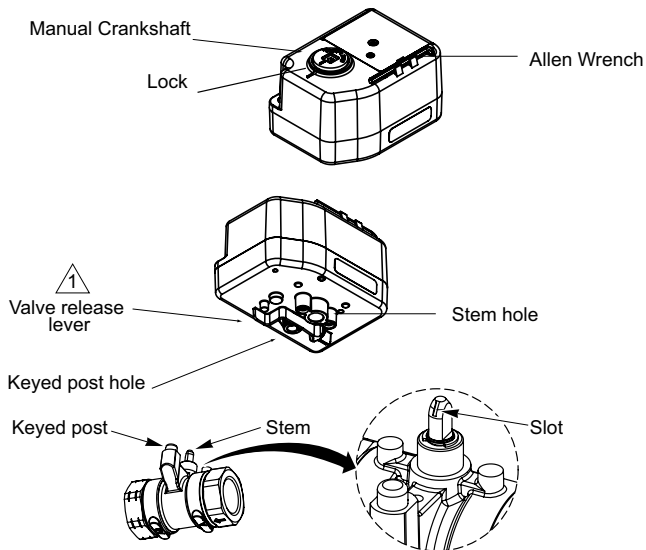

⚠ Parts on bottom of both actuators are identical.

Installing the Valve Body

Apply PTFE tape to the male pipe thread. Hand screw the pipe into the valve, turning it as far as it will go. Use a wrench to fully tighten the valve to the pipe. Do not over tighten or strip the threads.

Installing the Actuator on the Valve Body for M21xxxx Unit

1. Turn the valve stem so that the slot on the top of the stem is pointing towards the large keyed post. (see image above)
2. Align the valve body with the actuator to ensure the stem lines up with the large stem hole and the large keyed post lines up with the post hole on the bottom of the actuator.
3. Press the valve and actuator together to assemble.

Installing the Actuator on the Valve Body for M22xxxx Unit

1. Turn the valve stem so that the slot on the top of the stem is pointing towards the large keyed post.
2. Insert the allen wrench into the manual crank shaft on the top of the actuator. Crank eight turns in the direction indicated on the label. In the last turn, align the indicator notch to the opening in the crankshaft. Press the button around manual crankshaft to lock in place. Remove and replace allen wrench in cover slot.
3. Align the valve body with the actuator to ensure the stem lines up with the large stem hole and the large keyed post lines up with the post hole on the bottom of the actuator.
4. Press the valve and actuator together to assemble.
5. The first time the valve is operated electrically, the manual operating lever of the actuator will move to the automatic position. The manual operating lever can be used to allow flushing of the system after installation.

Removing the Actuator

1. Press and hold the valve release lever inward, towards the valve.
2. Lift the actuator from the valve.

Caution:

- Do not use the valve body to manually open the actuator as damage to the valve actuator will result.

Checkout

1. Make sure the valve stem rotates freely before and after installing the actuator.
2. If the stem does not operate freely it may indicate that the stem was damaged and may require that the valve be replaced.
3. After the piping is under pressure, check the valve body and the connections for leaks.
4. After the valve and actuator are installed, power the actuator and check the operation by varying the control signal. On spring return models, the valve should return to its normal position when power is removed.

Theory of Operation

When powered, the actuator moves to the desired position, winding the spring return system. When power is removed the spring returns the actuator to the normal position. This series of two-position spring return valve assemblies can be purchased with an optional built-in auxiliary SPDT end switch for interfacing or signaling; for example, zone pump burner control.

The auxiliary switch is designed for contact closure after the valve is more than 50% open. Do not exceed the published switch electrical ratings.

Manual override lever is designed to manually position the actuator to install on the valve or to manually position the valve. Turning the allen wrench in the manual crankshaft while power is applied or in the opposite direction as shown on the label will cause permanent damage. Use only the allen wrench provided with a maximum torque of 10 in-lb.

Caution



Do not use the allen wrench in the manual crankshaft while power is applied to the actuator. Manual positioning of the actuator while power is applied is NOT recommended.

Power Action

	Control Signal	Spring Return Open Actuator	Spring Return Closed Actuator
2-Position	Power On	A to AB Closed	A to AB Open
	Power Off	A to AB Open	A to AB Closed

* Two-Way valve operation described. For a three-way valve, A to AB operation is the same. B to AB operation is opposite that of A to AB operation.

Wiring

Make all connections according to job wiring diagrams and in compliance with local and national electrical codes. Refer to diagrams below for typical wiring.

Notice

- Multiple actuators may be connected to a single controller. Do not exceed the maximum current draw of the controller.
- Use of a properly sized, inherently limited, Class 2 transformer is recommended.
- Use only 18 to 24 AWG copper wire for all connectors.

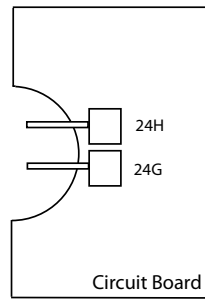

Wiring Terminals

Board Marking	Terminal Marking	AC Control Signal	DC Control Signal
24H	2	24v	+
24G	1	24v	-

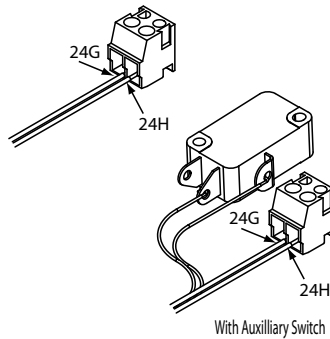

Maintenance

The ball valve assembly itself requires no maintenance. The stem and packing design eliminates the need for packing adjustment for the life of the valve. However, regular maintenance of the total heating and cooling system is recommended to ensure sustained optimum performance.

Field Repair

Neither valve nor actuator are field repairable. Replace entire unit as necessary.

Agency Listings

UL873: Underwriters laboratories (File #E9429 Category Temperature Indicating and Regulating Equipment) CUL: Listed for use in Canada by Underwriters Laboratory. Canadian Standards C22.2 No. 24. European Community: EMC Directive (2004/108/EC). Low Voltage Directive (72/23/EEC). Australia: This product meets requirements to bear the C-Tick Mark according to the terms specified by the Communications Authority under the Radio Communications Act of 1992.

Application Drawing

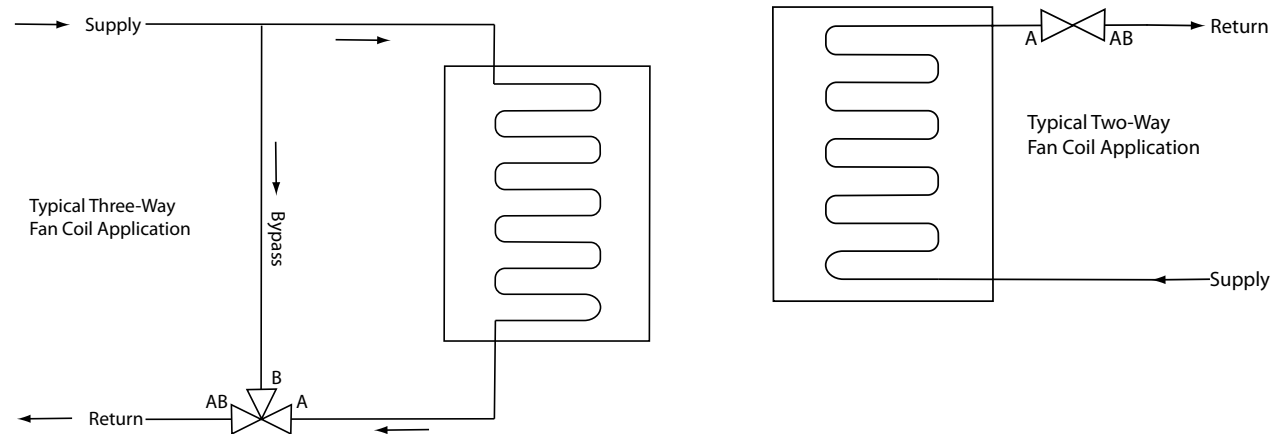

Note: Typical applications. For simplicity, balancing valves and control devices not shown.

Dimensions

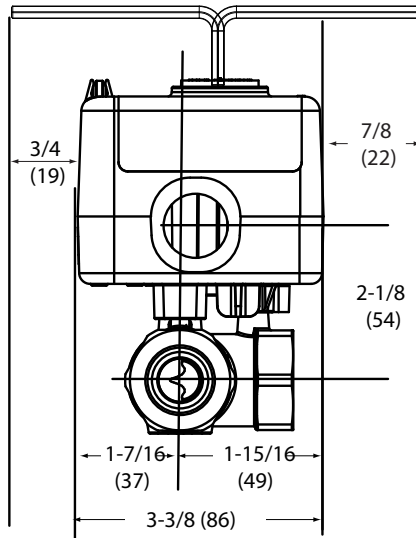
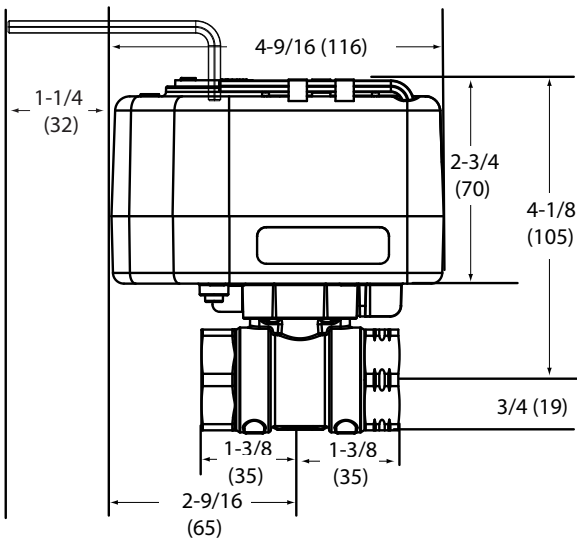
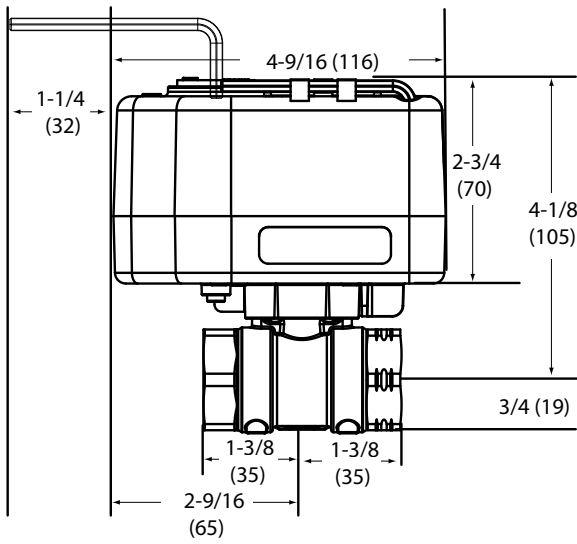

All dimensions shown in inches (mm) format and are rounded to the nearest 1/16".
 An additional 1 in (25 mm) is required to remove the actuator from the valve.