

# General Installation & Maintenance Instructions

**SERIES**

**ASCO S**

**General Service Solenoid Valves**  
**2 Way Internal Pilot-Operated**  
**3/8", 1/2", 3/4", 1", 1-1/4", 1-1/2" & 2" NPT**

**8238**

**I&M No.V 9503R4**

## DESCRIPTION

The 8238 series valves are 2-way, internal pilot-operated valves available in normally closed and normally open constructions. They are available either AC or DC operated with brass or stainless steel bodies. They come standard with DIN connection. Options are limited to flying leads, manual operators and some alternate elastomers. Dedicated constructions of the 8238 series are suitable for the following applications:

- General Service (air, inert gas, water & light oil)

## OPERATION

Refer to assembly drawing for flow diagrams and general instructions on operation.

## INSTALLATION

Check nameplate for correct catalog number, pressure, voltage, service and valve for any other special instruction tags or labels. Never apply incompatible fluids or exceed pressure rating of the valve. Installation and valve maintenance to be performed by qualified personnel.

### Future Service Considerations

Provision should be made for performing seat leakage, external leakage, and operational tests on the valve with a nonhazardous, noncombustible fluid after disassembly and reassembly.

### Temperature Limitations

Refer to ASCO S Catalog pages for specific valve series for ambient and fluid temperature limitations.

### Positioning

These valves are designed to perform properly when mounted in any position. However, for optimum life and performance, the valve should be mounted vertically and upright to reduce the possibility of foreign matter accumulating in the solenoid base sub-assembly area.

### Piping

Connect piping to valve according to markings on valve body (consult flow diagrams on assembly drawings). Apply pipe compound sparingly to male pipe threads only. If applied to valve threads the compound may enter the valve and cause operational difficulty. Avoid pipe strain by properly supporting and aligning piping. When tightening the pipe, do not use valve or solenoid as a lever. Locate wrenches applied to valve body or piping as close as possible to connection point.

**⚠ CAUTION: To avoid damage to the valve body, DO NOT OVERTIGHTEN PIPE CONNECTIONS. If TEFLON† tape, paste, spray or similar lubricant is used, use extra care when tightening due to reduced friction.**

**⚠ CAUTION: For the protection of the solenoid valve (all valves in general) install a strainer or filter suitable for the service involved in the inlet side as close to the valve as possible. Periodic cleaning is required depending on service conditions. See Series 8600, 8601 and 8602 for strainers.**

### Minimum Operating Pressure Differential

For all valves requiring a minimum operating pressure differential, the pressure and exhaust lines must be full size without restriction. Minimum operating pressure differential as stamped on the nameplate must be maintained for dependable operation.

## MAINTENANCE

**⚠ WARNING: To prevent the possibility of death, serious injury or property damage, turn off electrical power and depressurize valve. If the valve handles combustible fluid, extinguish all open flames and avoid any type of sparking or ignition. Vent fluid to a safe area before servicing the valve.**

NOTE: For most valves it is not necessary to remove valve from pipeline for repairs.

## Wiring

Wiring must comply with local codes and the National Electrical Code. To facilitate wiring, the solenoid may be rotated 360°.

## Solenoid Temperature

Standard valves are supplied with coils designed for continuous duty service. When the solenoid is energized for a long period, the solenoid becomes hot and can be touched by hand only for an instant. This is a safe operating temperature. Any excessive heating will be indicated by the smoke and odor of burning coil insulation.

## Cleaning

All solenoid valves should be cleaned periodically. The time between cleanings will vary depending on the medium and service conditions. In general, if the voltage to the coil is correct, sluggish valve operation, excessive noise or leakage will indicate that cleaning is required. In the extreme case, faulty valve operation will occur and the valve may fail to shift. Clean strainer or filter when cleaning the valve.

## Preventive Maintenance

- Keep medium flowing through valve as free from dirt and foreign material as possible.
- Periodic exercise of the valve should be considered if ambient or fluid conditions are such that corrosion, elastomer degradation, fluid contamination build up, or other conditions that could impede solenoid valve shifting are possible. The actual frequency of exercise necessary will depend on specific operating conditions. A successful operating history is the best indication of a proper interval between exercise cycles.
- Depending on the medium and service conditions, periodic inspection of internal valve parts for damage or excessive wear is recommended. Thoroughly clean all parts. If parts are worn or damaged, install a complete ASCO S rebuild kit.

## Causes Of Improper Operation

- **Faulty Control Circuits:** Check the electrical system by energizing the solenoid. A metallic *click* signifies that the solenoid is operating. Absence of the *click* indicates loss of power supply. Check for loose or blown fuses, open circuited or grounded coil, broken lead wires, or splice connections.
- **Burned-Out Coil:** Check for open-circuited coil. Replace coil as necessary. Check supply voltage; it must be the same as specified on nameplate and as marked on the coil.
- **Low Voltage:** Check coil voltage across coil leads. Voltage must be at least 85% of nameplate rating.
- **Incorrect Pressure:** Check valve pressure. Pressure to valve must be within range specified on nameplate.
- **Excessive Leakage:** Disassemble valve and clean all parts. Replace worn or damaged parts with a complete ASCO S Rebuild Kit for best results.

**⚠ WARNING: To prevent the possibility of death, serious injury or property damage, check valve for proper operation before returning to service. Also perform internal seat and external leakage tests with a nonhazardous, noncombustible fluid.**

## ORDERING INFORMATION

### FOR ASCO S REBUILD KITS AND COIL KITS

Parts marked with an asterisk (\*) on the assembly drawing are supplied in Rebuild Kits. When Ordering Rebuild Kits for ASCO S valves, order the Rebuild Kit number stamped on the valve nameplate. Parts marked with an triangle (▲) on the assembly drawing are supplied in Coil Kits. When Ordering Coils for ASCO S valves, order the number stamped on your coil. If the number of the kit or the coil is not visible, order by indicating the number of kits required, and the Catalog Number and Serial Number of the valve(s) for which they are intended.

† DuPont Co. Registered Trademark

**ASCO S**

Page 1 of 3

## Torque Chart

Catalog Number	solenoid base sub assembly	bonnet screw	solenoid base screw
8238S414, 8238S415, 8238S416, 8238S417	3–3.5 Nm 26.5–31 in–lbs	0.8–1.2 Nm 7.1–10.6 in–lbs	–
8238S402, 8238S405, 8238S421, 8238S422	–	3–3.5 Nm 26.5–31 in–lbs	0.8–1.2 Nm 7.1–10.6 in–lbs
8238S408, 8238S410, 8238S423, 8238S424	–	9–10 Nm 79.6–88.5 in–lbs	0.8–1.2 Nm 7.1–10.6 in–lbs
8238S404, 8238S406	–	3–3.5 Nm 26.5–31 in–lbs	–
8238S407, 8238S409	–	9–10 Nm 79.6–88.5 in–lbs	–
8238S411, 8238S412, 8238S413 8238S418, 8238S419, 8238S420	–	12–13 Nm 106.1–114.9 in–lbs	1.6–2 Nm 14.2–17.7 in–lbs
8238S401	–	1.6–2 Nm 14.2–17.7 in–lbs	–
8238T402, 8238T405 8238T414 8238T415, 8238T425, 8238T426	5–7 Nm 44.2–61.9 in–lbs	1.6–2 Nm 14.2–17.7 in–lbs	–
8238T408, 8238T410 8238T416, 8238T417	5–7 Nm 44.2–61.9 in–lbs	9–10 Nm 79.6–88.5 in–lbs	–

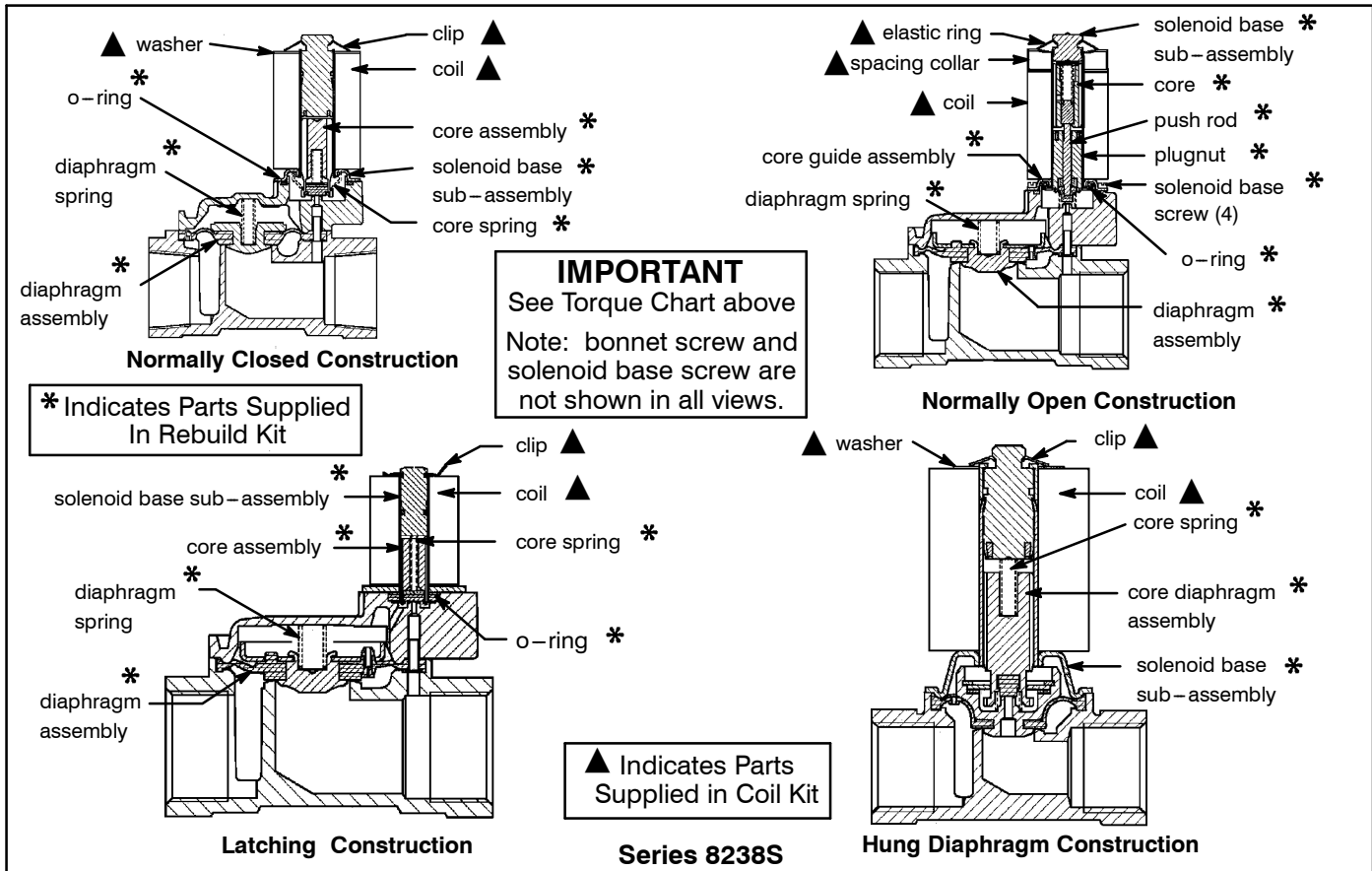

**IMPORTANT**  
 See Torque Chart  
 on page 2 of 3  
 Note: bonnet screw is  
 not shown in all views.

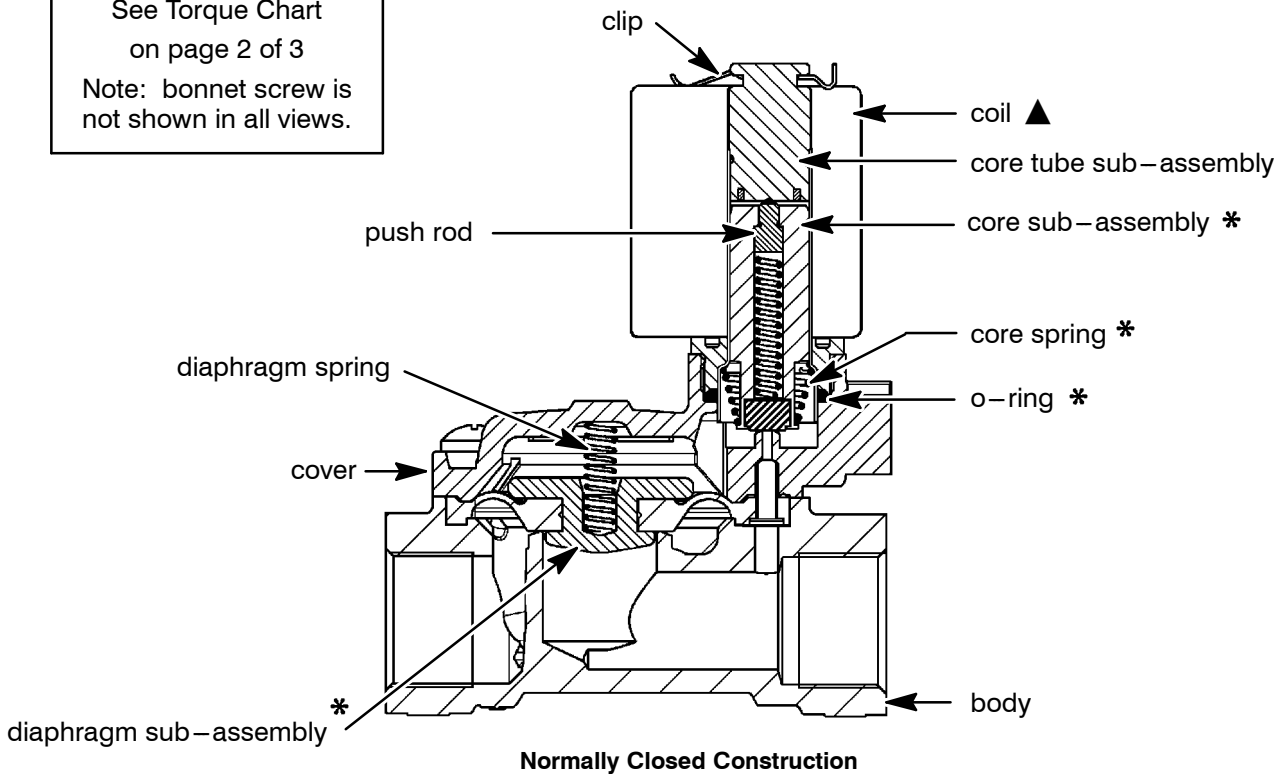

\* Indicates Parts Supplied  
 In Rebuild Kit

▲ Indicates Parts  
 Supplied in Coil Kit

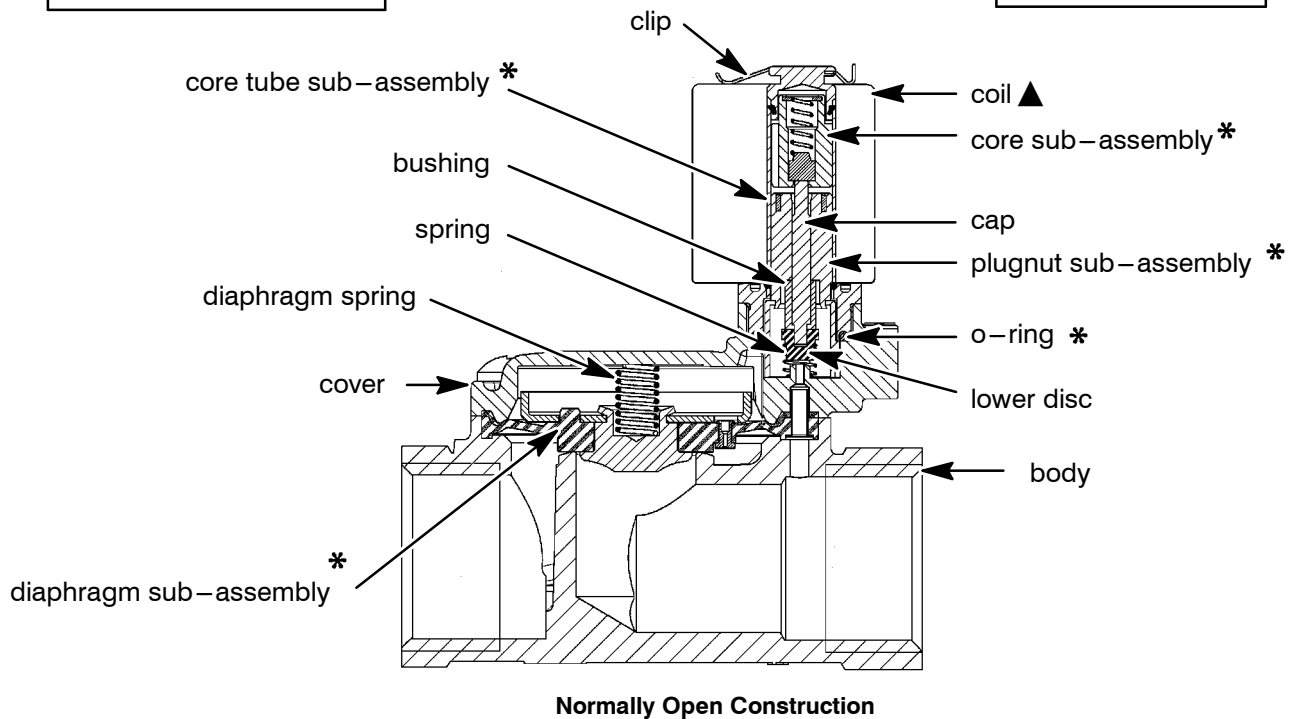

**Series 8238T**