

Multi-Purpose Tool for Solenoid Valves

The Emerson Multi-Purpose Solenoid Tool incorporates a variety of useful service functions into a single precision unit.

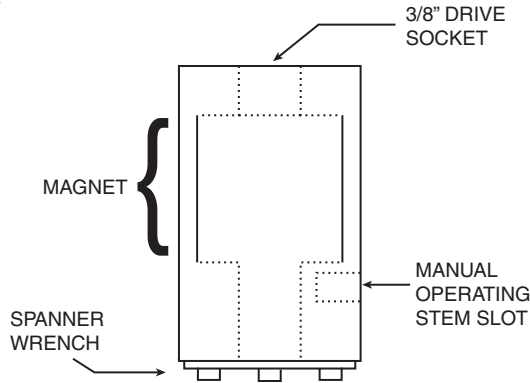

Figure 1

1) **Magnetic tool**

To open a normally closed Emerson Solenoid valve, that is in the de-energized state and has no manual stem, place the tool over the enclosing tube. The magnetic field will immediately draw the plunger upwards to the open position. The magnet will open a solenoid valve up to 300 psi system pressure differential. See Figure 2.

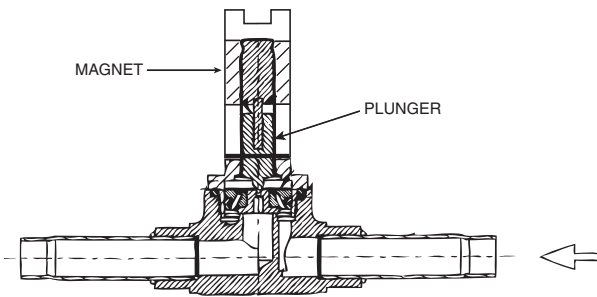

Figure 2

2) **Spanner Wrench tool**

To disassemble an Emerson solenoid valve for repair: Place the tool over the enclosing tube and align the three spanner prongs with the recesses in the collar at the base of the tube. See Figure 3. Insert a ratchet with a 3/8" drive into the socket and turn counterclockwise to remove the enclosing tube and collar assembly. After repair, reassemble valve with proper torque specifications on collar:

- 100RB Series 225 in. lbs.
- 240RA Series 150 in. lbs.
- 540RA Series 150 in. lbs.

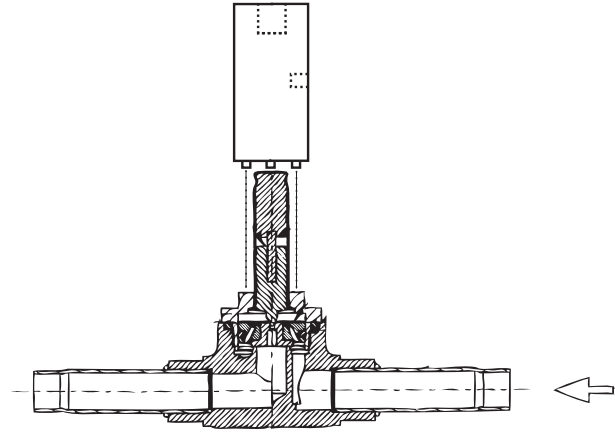

Figure 3

NOTE: If valve is of an older Emerson design with 2 spanner recesses use Emerson's old design tool X-11981.

3) **Manual Stem Adjustment tool**

To operate an Emerson valve with manual stem: Remove the stem cap and insert manual stem into manual stem slot, turning counterclockwise to open valve. See Figure 4.

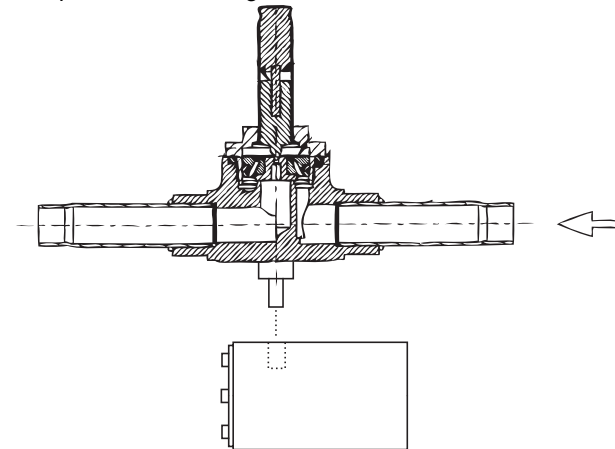

Figure 4

WARNING

Strong Magnetic Field.

Even if packaged, keep tool at least 24" away from:

1. Pacemakers and other electronic cardiac care devices.
2. Computers, display screens, discs, tapes, phones, blackberries, pdas, etc.
3. Magnetic strip devices including credit cards.

Failure to comply could result in bodily injury or property damage.