

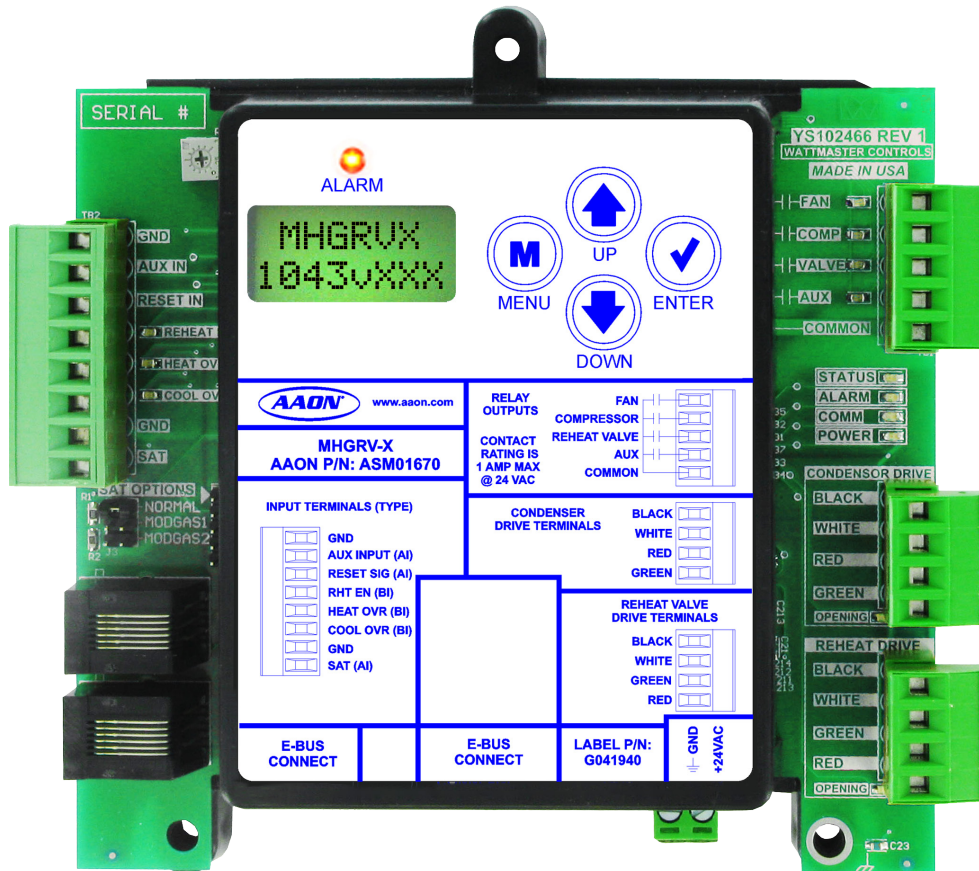

MHGRV-X Controller Field Technical Guide



MHGRV-X REVISION LOG

REVISION AND DATE	CHANGE
Rev. N, March 25, 2021	Updated part numbers, alarms and alarm history. Added Figure/Table content pages, and Fahrenheit/Celsius temperature conversion

MHGRV-X PARTS REFERENCE

PART DESCRIPTION	PART NUMBER
MHGRV-X	ASM01670
MODGAS-X Controller	ASM01668
VCCX2 Controller	ASM01698
AAON Unit Controller	Varies
Supply Air Temperature Sensor	G051240 (6") G051250 (12")
Unit Controller	Varies
Reheat Expansion Module	ASM01687
EBC E-BUS Cable Assembly E-BUS Power and Comm 1.5 Ft, 3 Ft, 10 Ft, 25 Ft, 50 Ft, 75 Ft, 100 Ft, 150 Ft, 250 Ft, and 1000 Foot Spool	G029440 (1.5 Ft), G012870 (3 Ft), G029460 (10 Ft), G045270 (25 Ft), G029510 (50 Ft), G029530 (75 Ft), G029450 (100 Ft), G029470 (150 Ft), V36590 (250 Ft), G018870 (SPOOL)



www.aaon.com

**All manuals are also available for download from
www.aaon.com/controlsmanuals.**

AAON
2425 South Yukon Ave.
Tulsa, OK 74107-2728
www.aaon.com
Factory Technical Support Phone: 918-382-6450
AAON Controls Support: 866-918-1100
It is the intent of AAON to provide accurate and current product information. However, in the interest of product improvement, AAON reserves the right to change pricing, specifications, and/or design of its product without notice, obligation, or liability.

AAON P/N: G086630, Rev. N
© March 2021 AAON Inc. All rights reserved throughout the world.
AAON® is a registered trademark of AAON, Inc., Tulsa, OK. AAON assumes no responsibility for errors or omissions in this document.
This document is subject to change without notice.

OVERVIEW 5
 MHGRV-X General Information..... 5

WIRING 6
 Installation and Wiring..... 6
 MHGRV-X to AAON unit controller Wiring..... 7
 MHGRV-X Stand-Alone Wiring 8

INPUTS AND OUTPUTS 9
 Inputs and Outputs..... 9

OPERATION MODES 10
 Operation Modes 10

LCD SCREENS 12
 Navigation Keys 12
 Main Screens Map and Main MHG REHEAT Screens 13
 Status and Alarm Screens 14
 Setpoint and Force Valves Screens 15

TROUBLESHOOTING 16
 LED Diagnostics 16
 Alarms 17
 Other Checks 18

APPENDIX A: SAT SENSOR..... 20
 Supply Air Temperature Sensor Installation 20
 SAT Sensor Wiring Guide and Jumper Settings 21

APPENDIX B: MHGRV II..... 22
 MHGRV-X Replacement of MHGRV II..... 22

APPENDIX C: REHEAT EXPANSION MODULE 23
 Features and Dimensions 23
 Installation and Wiring..... 24
 Wiring 25
 Operation Modes 26
 LED Diagnostics and Troubleshooting 27
 Troubleshooting 28

FIGURES

Figure 1:	MHGRV-X Dimensions	5
Figure 2:	MHGRV-X to AAON unit controller Wiring	7
Figure 3:	MHGRV-X Stand-Alone Wiring.....	8
Figure 4:	LCD Display and Navigation Keys.....	12
Figure 5:	MHGRV-X LED Locations and Descriptions	17
Figure 6:	Supply Air Temperature Sensor Installation	20
Figure 7:	MHGRV-X	22
Figure 8:	Reheat Expansion Module and Mounting Plate Dimensions	23
Figure 9:	Reheat Expansion Module(s) Wiring	25
Figure 10:	Reheat Expansion LED Locations and Descriptions	27

TABLES

Table 1:	MHGRV-X Electrical and Environmental Requirements	6
Table 2:	MHGRV-X Inputs and Outputs	9
Table 3:	Navigation Key Functions	12
Table 4:	STATUS LED Blink Codes.....	16
Table 5:	ALARM LED Blink Codes	16
Table 6:	0-3V Temperature Sensor - Voltage and Resistance for Type III Sensors	18
Table 7:	0-5V Temperature Sensor - Voltage and Resistance for Type III Sensors	19
Table 8:	SAT Wiring Conditions	21
Table 9:	Stand-Alone Mode SAT OPTIONS Jumper Settings.....	21
Table 10:	Communications Mode SAT OPTIONS Jumper Settings.....	21
Table 11:	Reheat Expansion Module ALARM LED Blink Codes	27

MHGRV-X General Information

Overview

The MHGRV-X is designed to control a Modulating Hot Gas Reheat Valve to maintain a desired Supply Air Temperature setpoint. The controller can be used as a stand-alone controller or can be used in conjunction with any AAON unit controller.

In addition, up to seven Reheat Expansion Modules can be connected to the Controller and to each other for additional Reheat Valve Control.

The MHGRV-X connects to an AAON unit controller or expansion module via a modular cable. Depending on the type of unit controller, this connection will utilize an I²C connection or an E-BUS connection.

When using the MHGRV-X to replace an existing MHGRV II Controller, see **Appendix B, page 22** for details. See **Figure 1, this page** for dimensions.

Features

The MHGRV-X provides the following:

- Can be operated as a stand-alone controller or communicating with AAON unit controllers.
- Provides for Supply Air Temperature Setpoint reset when required.
- Second stage reheat capability when using two Hot Gas Reheat Valves.
- Control of the reheat solenoid valve to provide coil flushing for positive refrigerant oil return.
- Can provide further Reheat control using up to seven Reheat Expansion Modules.
- Contains a 2 x 8 LCD character display and four buttons that allow for status display, setpoint changes, and configuration changes

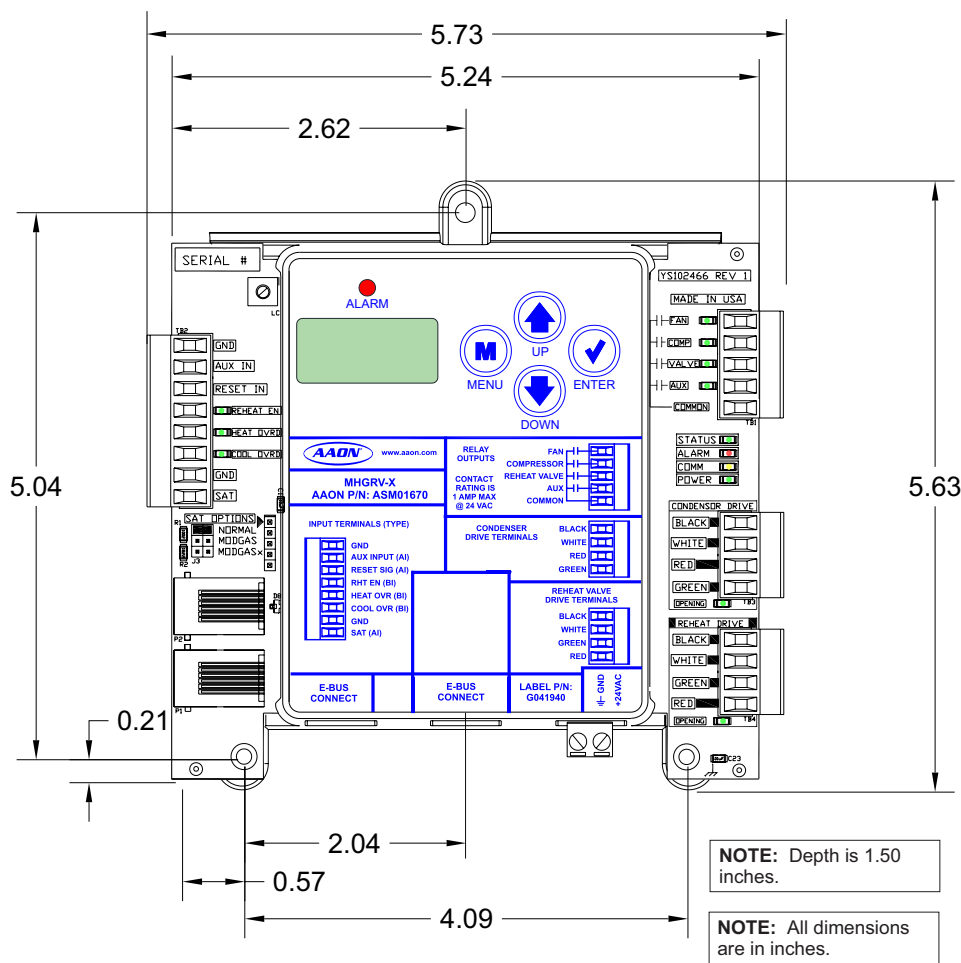

Figure 1: MHGRV-X Dimensions

Installation and Wiring

Installation and Mounting

The MHGRV-X is housed in a plastic enclosure. It is designed to be mounted by using the three mounting holes in the enclosure base. It is important to mount the module in a location that is free from extreme high or low temperatures, moisture, dust, and dirt. Be careful not to damage the electronic components when mounting the module.

NOTE: The MHGRV-X contains no user-serviceable parts. Contact qualified technical personnel if your Controller or Module is not operating correctly.

Wiring

The modules must be connected to an 18-30 VAC power source of the proper size for the calculated VA load requirements. All transformer sizing should be based on the VA ratings listed in **Table 1, this page.**

Control Device	Voltage	VA Load	Operating Temperature	Humidity (Non-Condensing)
MHGRV-X	18-30VAC	18	-22°F to 158°F* -30°C to 70°C*	0-95% RH
	Inputs		Resistive Inputs require 10KΩ Type 3 Thermistor	
	Outputs		24VAC Inputs provide 4.7KΩ Load	Relay Outputs: 1 Amp maximum per output.

Table 1: MHGRV-X Electrical and Environmental Requirements

NOTE: If the temperature at the controller is below -22°F (-30°C), the display refresh rate could be less responsive.

WARNING: When using a single transformer to power more than one controller or expansion module, the correct polarity must always be maintained between the boards. Failure to observe correct polarity will result in damage to the Unit Controller, MHGRV-X, and any associated modules.

Please carefully read and apply the following information when wiring the Unit Controller, MHGRV-X and any associated module.

1. All wiring is to be in accordance with local and national electrical codes and specifications.
2. All 24 VAC wiring must be connected so that all ground wires remain common. Failure to follow this procedure can result in damage to the controller and connected devices.
3. Minimum wire size for 24 VAC wiring should be 18-gauge.
4. Minimum wire size for all sensors should be 24-gauge. Some sensors require two-conductor wire and some require 3-or 4-conductor wire.
5. Minimum wire size for 24 VAC thermostat wiring should be 22-gauge.
6. Be sure that all wiring connections are properly inserted and tightened into the terminal blocks. Do not allow wire strands to stick out and touch adjoining terminals which could potentially cause a short circuit.
7. When communication wiring is to be used to interconnect HVAC unit controllers together or to connect to other communication devices, all wiring must be plenum-rated, minimum 18-gauge, two-conductor, twisted pair with shield. AAON can supply communication wire that meets this specification and is color coded for the network or local loop. Please consult your AAON distributor for information. If desired, Belden #82760 or equivalent wire may also be used.
8. Before applying power to the HVAC unit controller, MHGRV-X, and any associated modules, be sure to recheck all wiring connections and terminations thoroughly.

Powering Up

When the Controller and Modules are first powered up, the POWER LED should light up and stay on continuously. If it does not light up, check to be sure that you have 24 VAC connected to the controller, that the wiring connections are tight, and that they are wired for the correct polarity. The 24 VAC power must be connected so that all ground wires remain common. If after making all these checks, the POWER LED does not light up, please contact AAON Controls Support for assistance.

MHGRV-X to AAON Unit Controller Wiring

Communications Wiring

For connection to a VCCX2 or VCB-X Controller, VCCX2 or VCB-X Expansion Module, and Reheat Expansion Module, use an E-BUS Cable to connect to the appropriate E-BUS port on those modules and/or controller.

For all other controllers, including the VAV/CAV, MUA, VCM, VCM-X, SA, and RNE Controllers, use an I²C Cable connecting to the appropriate I²C ports on those controllers.

When connected to an AAON unit controller, the Supply Air Temperature Sensor is attached to the AAON unit controller. See **Figure 2, this page.**

See the SAT Wiring Conditions Table and SAT OPTIONS jumper settings in **Tables 8 and 10, page 21.**

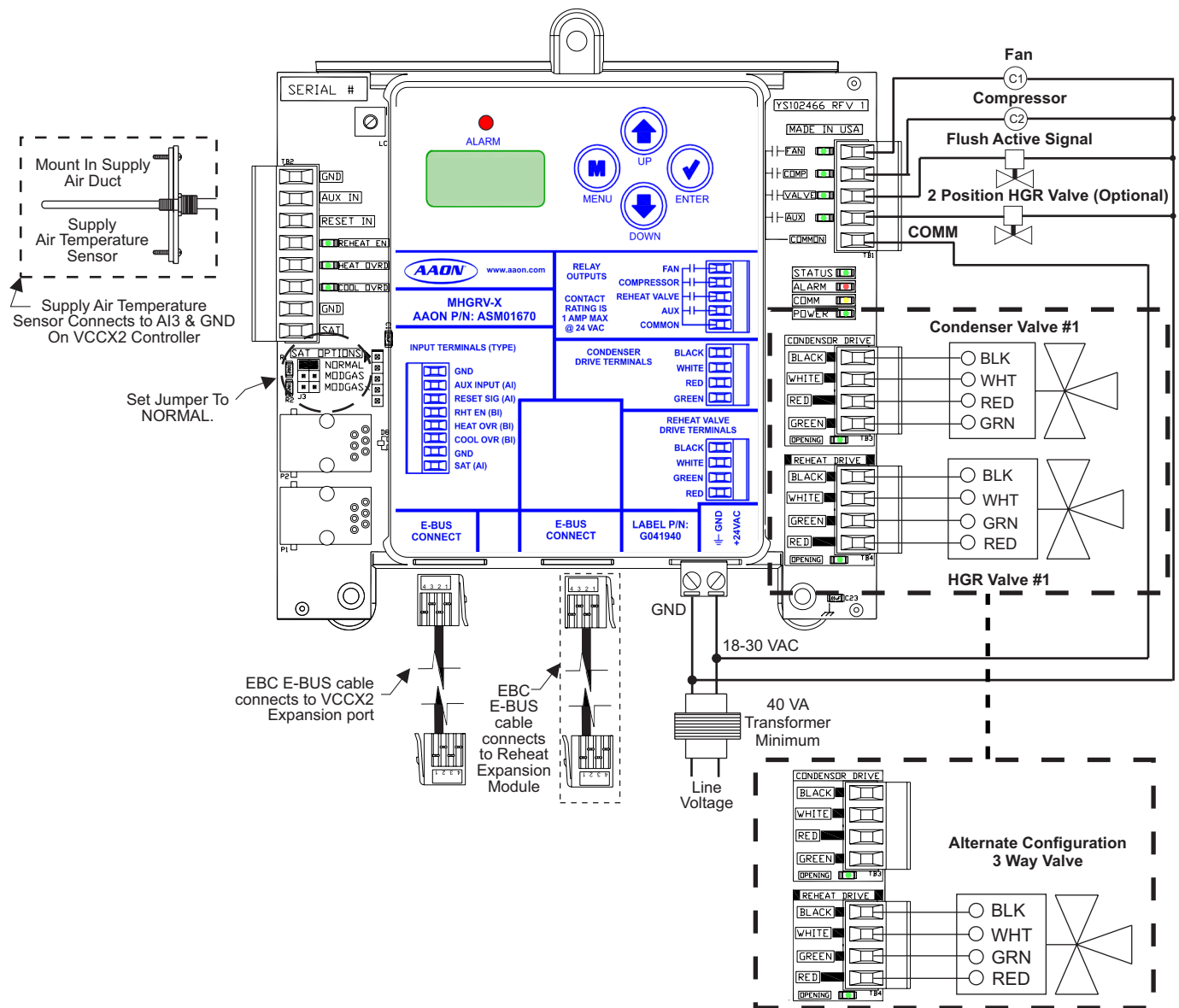

Figure 2: MHGRV-X to AAON Unit Controller Wiring

WIRING

MHGRV-X Stand-Alone Wiring

Stand-Alone Wiring

In Stand-Alone Mode, the MHGRV-X connects to the E-BUS port of the Reheat Expansion Module with an EBC E-BUS cable. See **Figure 3, this page.**

See the SAT Wiring Conditions Table and SAT OPTIONS Jumper Settings in **Tables 8 and 9, page 21.**

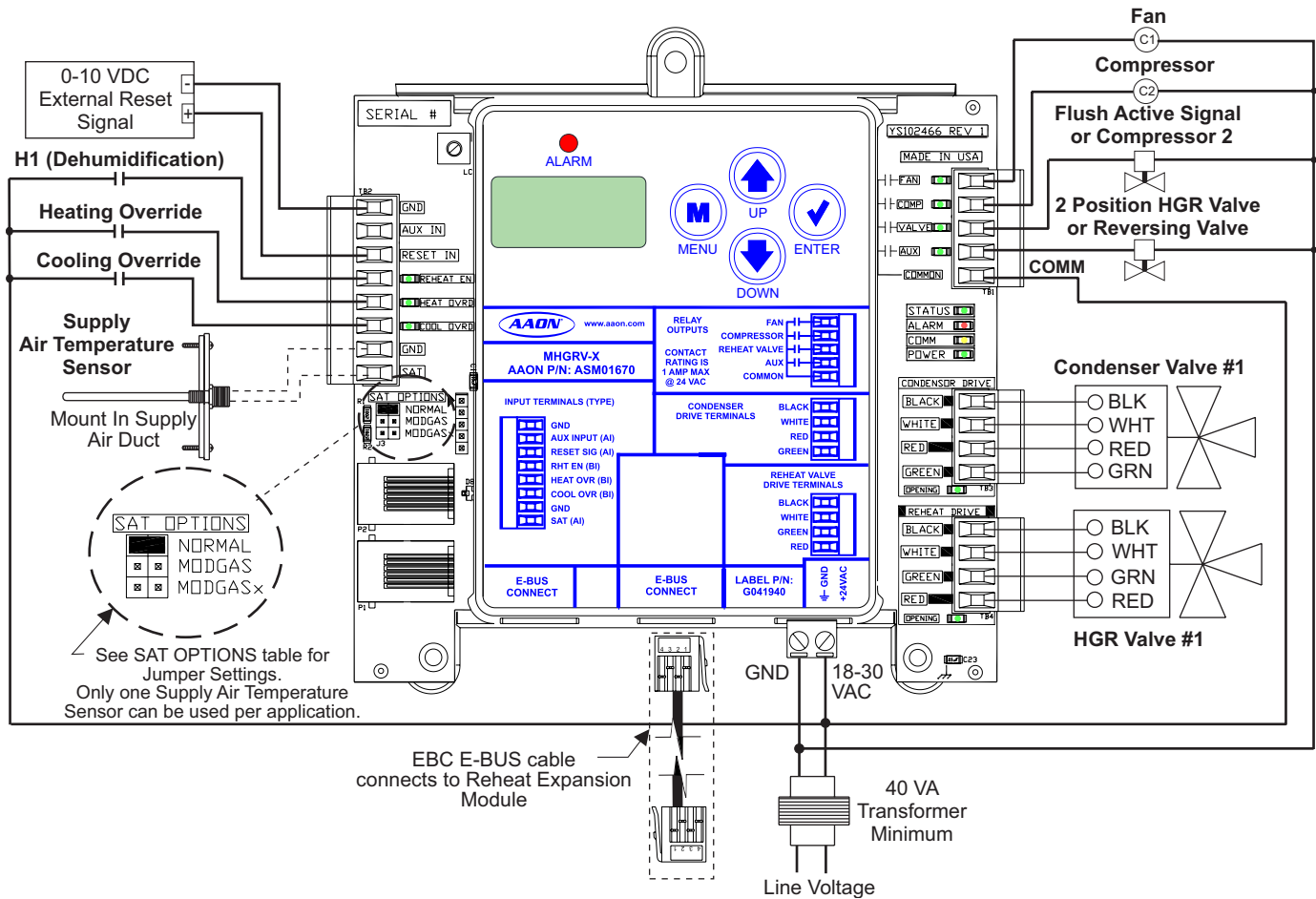

Figure 3: MHGRV-X Stand-Alone Wiring

I/O Map

The following inputs and outputs are available on the MHGRV-X. See **Table 2, this page** to reference the Input/Output Map.

ANALOG INPUTS	
1	Supply Temperature
2	Reset Signal
3	AUX Input
BINARY INPUTS	
1	Reheat Enable
2	Heating Override
3	Cooling Override
RELAYS	
1	Fan
2	Compressor
3	Flush Active Signal / Compressor 2
4	Auxiliary / Reversing Valve

Table 2: MHGRV-X Inputs and Outputs

NOTE: All analog and 24 VAC contact closure inputs are used only in Stand-Alone operation.

Analog Inputs

SAT: Supply Air Temperature Sensor

Used in Stand-Alone operation and when MODGAS is connected to a CAV/VAV or MUA controller. The Supply Air Temperature Sensor is the main control input. This sensor has to be installed for the unit to operate. The Supply Air Temperature Sensor is located in the discharge air stream and monitors the HVAC unit's Supply Air Temperature to maintain the Supply Air Temperature Setpoint.

RST IN: Reset Signal

Used only in Stand-Alone operation. The Discharge Temperature Setpoint can be reset by supplying a 0-10 VDC signal to the RESET IN low voltage terminal block. This reset signal is optional and need only be used if you require resetting of the discharge air temperature.

AUX IN: Auxiliary Reheat Valve Input

Used when AUX mode is configured as enabled. This input looks at a 0-10 VDC signal to control the valve position.

- 0VDC = 0% Reheat Valve position
- 5VDC = 50% Reheat Valve position
- 10VDC = 100% Reheat Valve position.

Binary Inputs

REHEAT EN: Reheat Enable Contact

Used only in Stand-Alone operation. When a call for dehumidification is initiated by another controller, this interlocked 24 VAC wet contact closure is used to enable the MHGRV-X.

HEAT OVR: Heating Override

Used only in Stand-Alone operation. When a call for heating is initiated by the HVAC unit, this interlocked 24 VAC wet contact closure is used to override the MHGRV-X Dehumidification Mode.

COOL OVR: Cooling Override

Used only in Stand-Alone operation. When a call for cooling is initiated by the HVAC unit, this interlocked 24 VAC wet contact closure is used to override the MHGRV-X Dehumidification Mode.

Relay Outputs

FAN: Fan Enable

When a call for Dehumidification, Cooling Override, or Heating Override is received, this relay will be closed to energize the HVAC unit Supply Fan.

CMP: Compressor Enable

When a call for Dehumidification or Cooling Override is received, this relay will be closed to energize the Compressor(s).

VALVE: Flush Active Signal / Compressor 2

If configured as Flush, this relay will be active any time a Flush Cycle is active. When the Flush Cycle ends this relay will turn off until the next flush occurs.

If configured as Compressor 2, this relay will be used to control a second Compressor when there is a call for Dehumidification. Compressor 2 will come on 30 seconds after the first Compressor activates. Compressor 2 has a minimum run time of 10 minutes, and will turn off if the Reheat Valve is at 100% and the Supply Air Temperature is 5°F below setpoint for one minute. After being off for 10 minutes, it can come back on if the Supply Air Temperature is 5°F above setpoint and the valve is at 0%.

OPERATION MODES

Modes of Operation

AUX: Two-Position HGR Valve / Reversing Valve

If configured as standard, this relay will be used to control a two-position HGR valve. Used on larger capacity systems that have an optional two-position HGR Valve in addition to the Modulating HGR Valve. When a call for Dehumidification is received, if the modulating HGR valve is at 100% and the Supply Air Temperature is at least 5°F below setpoint, this relay output will energize to enable the two-position HGR valve. The relay will de-energize when the modulating HGR valve closes to 0% and the Supply Air Temperature is at least 5°F above setpoint.

The modulating valve is then enabled to modulate to maintain the Supply Air Temperature Setpoint.

If configured as Reversing Valve, this relay will control a Reversing Valve on a Heat Pump unit. Any time there is a call for Cooling or Dehumidification, this relay will be energized.

COM: Relay Common

Requires 24 VAC from transformer.

Initialization

The MHGRV-X uses on-board LEDs to indicate various diagnostic conditions during power-up and operation. It also uses the LCD Display to show initialization. Please review this information for a complete description of the controller initialization sequence.

Modulating Hot Gas Valves

The MHGRV-X utilizes two modulating valves to control the flow of Hot Gas through the Hot Gas Reheat Coil. One of these valves is the Condenser Hot Gas Valve and the other is the Hot Gas Reheat Valve. The valves are wired to the MHGRV-X Modulating Hot Gas Valve Output terminals. These valves work in concert with each other to create a “three-way valve” configuration. As one closes, the other opens, etc. All modes of operation that follow referring to the Hot Gas Reheat Valve are actually a combination of these two valves working together to achieve the specified sequence of operation.

NOTE: Some units use a three-way valve instead of two separate valves. The three way valve is wired to the Reheat terminal block.

Modes of Operation

The MHGRV-X can be used in two different modes of operation. These modes behave in a similar manner; the main difference is the way they receive information to control the dehumidification process. The following is a description of these modes:

Stand-Alone Operation

As the name implies, in this mode the controller behaves as an independent unit. The controller begins the dehumidification process when the Dehumidification Input “H1” receives a 24 VAC signal from an outside source. When the signal is received, the controller will activate the “FAN” output to energize the HVAC unit fan. At the same time, the controller will initiate Cooling Mode by energizing the “CMP” output starting the HVAC unit compressor. In addition, the controller will open the Hot Gas Reheat Coil by activating the “VALVE” output. At this time, the MHGRV-X will start to modulate the Modulating Hot Gas Reheat Valve. The controller will modulate the MHGR valve to maintain the Supply Air Temperature Setpoint by activating the stepper motor outputs on the MHGR Valve.

The Supply Air Setpoint is configured with the Setpoint Screen in the LCD Display. If Supply Air Temperature Reset is used, it will initiate when a 0-10 VDC signal is supplied to the “RESET IN” input. As the voltage increases from 0 to 10 volts at the “RESET IN” input, the Supply Air Temperature will be reset towards the Supply Air Reset Temperature Setpoint. This setpoint is configured with the Setpoint Screen in the LCD Display. When a 10-volt input signal is received at the “RESET IN” input, it will be controlling at the Supply Air Temperature Reset Setpoint. The controller will conclude the Dehumidification process when input “H1” is deactivated, the input “Cool Override” is activated, or the input “Heat Override” is activated.

Auxiliary Mode Stand-Alone

1. Auxiliary Mode Operation needs to be configured first from the display.
2. This mode will be activated if the Reheat Enable input is enabled. Any expansion boards that are enabled will follow.
3. Reheat Valve
 - The unit will keep the valve off for the first 30 seconds
 - Then it will modulate the valve between 0% to 100% to match the 0-10 VDC Auxiliary Analog input.
4. The Unit will exit Reheat Mode when the Reheat input is disabled. The expansion modules will do the same.

5. Relay Operation

- Fan Relay will be activated in this mode.
- Compressor Relay will be activated in this mode.
- Valve Relay will be activated in this mode after the initial 30 seconds.
- Auxiliary Relay
 - It will be activated if the Reheat Valve stays at 100% for two minutes and the Supply Air Temperature is 5°F below the Supply Air Setpoint.
 - It will deactivate if the Reheat Valve stays at 0% for two minutes and the Supply Air Temperature is 5°F above the Supply Air Setpoint.

Communications Operation

In this mode, the MHGRV-X behaves as an expansion board for an AAON unit controller. The controller begins the dehumidification process when the AAON unit controller makes a request to the MHGRV-X for dehumidification. At that time, the controller will activate the “FAN” output to energize the HVAC unit fan. At the same time, the controller will initiate Cooling Mode by energizing the “CMP” output starting the HVAC unit compressor.

In addition, the MHGRV-X will open the Hot Gas Reheat Coil by activating the “VALVE” output which opens the Reheat Solenoid Valve. At this time, the MHGRV-X will start to modulate the Modulating Hot Gas Reheat Valve. The controller will modulate the MHGR valve to maintain the Supply Air Temperature Setpoint by activating the stepper motor outputs on the MHGR valve. The Supply Air Setpoint is set by programming the HVAC unit controller. If Supply Air Temperature Reset is used, it will initiate when the HVAC unit controller ends a request to reset the Supply Air Temperature.

The Supply Air Temperature will be reset towards the Supply Air Reset Temperature Setpoint stored in the HVAC unit controller. It will send a request to move towards the Supply Air Temperature Reset Setpoint based on its setpoints and configuration.

The controller will conclude the Dehumidification process when the HVAC unit controller sends a request to terminate Dehumidification or a Cooling or Heating Override request is made by the HVAC unit controller. Any setpoints or signals at the inputs to the MHGRV-X will be ignored.

Auxiliary Mode Communicating

1. Same as the Stand-Alone Auxiliary Mode, but the Reheat Enable and Auxiliary Valve position will be sent using E-BUS commands.

Additional Features

Reheat Coil Flush

To assure positive oil return to the compressor, the Hot Gas Reheat Coil will be flushed of liquid refrigerant by moving the Modulating Gas Reheat Valve to its maximum position for a short interval.

Cooling Flush

If the unit is in cooling mode, a flush will occur when the unit’s flush cooling interval timer has elapsed. The time is accumulated whenever it is in cooling mode and resets after each flush cycle. The flush cooling interval timer is a setpoint that is configurable using the keypad and display (0 to 120 minutes in 10 minute increments).

Reheat Mode Flush

If the unit is in dehumidification mode and the valve is below 70% for the flush reheat interval timer value, a flush will occur. If the valve goes above 70%, the timer is reset. The flush reheat interval timer is a setpoint that is configurable using the keypad and display (0 to 120 minutes in 10 minute increments).

Condenser Coil Flush

If Condenser Coil Flush is configured and the unit is in Dehumidification Mode and the reheat valve is above 70% for the flush reheat interval timer value, a condenser flush will occur. This shares the timer with the reheat flush so if the valve is below 70% a Reheat Flush would occur.

Optional Second Stage Reheat

On larger systems, where more hot gas reheat capacity may be required, a two-position Hot Gas Reheat Valve can be connected to the MHGRV-X to be used in conjunction with the Modulating Hot Gas Reheat Valve. Any time the reheat demand moves above the Modulating Hot Gas Reheat Valve capacity, this two-position valve would be energized to supply additional hot gas to the Hot Gas Reheat Coil. As the reheat demand is satisfied, the MHGRV-X will de-energize the two-position valve and control reheat with the Modulating Hot Gas Reheat Valve.

Navigation Keys

LCD Display Screen and Navigation Keys

The LCD display screens and buttons allow you to view status and alarms, and enable force modes. See **Figure 4, this page** and refer to **Table 3, this page** for descriptions.

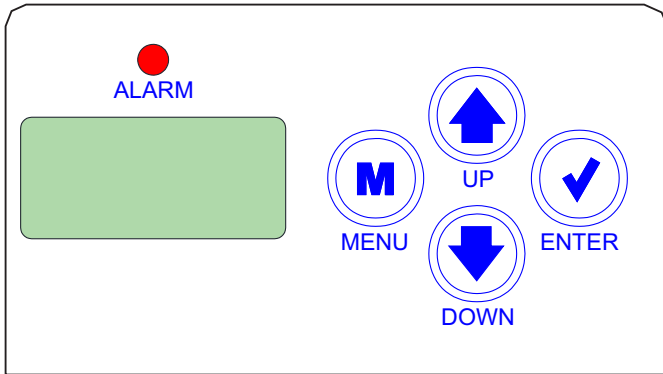

Figure 4: LCD Display and Navigation Keys





NAVIGATION KEY	KEY FUNCTION
MENU 	Use the MENU key to move through screens within Main Menu categories and return to the Main Menu while at other screens.
UP 	Use this key to adjust setpoints and change configurations.
DOWN 	Use this key to adjust setpoints and change configurations.
ENTER 	Use the ENTER key to navigate through the Main Menu Screen categories.

Table 3: Navigation Key Functions

Main Screens Map and Main MHG REHEAT Screens

Main Screens Map

Refer to the following map when navigating through the LCD Main Screens. The first screen is an initialization screen. To scroll through the rest of the screens, press the **<MENU>** button.

INIT
VALVE

MHG
REHEAT

Press  to scroll through MHG REHEAT Screens.

Press  to go to STATUS Screens.

STATUS
SCREEN

Press  to scroll through STATUS Screens.

Press  to go to ALARMS Screens.

ALARMS

Press  to scroll through ALARMS Screens.

Press  to go to SETPOINTS Screens.

SETPOINT

Press  to scroll through SETPOINT Screens.

Press  to go to FORCE VALVE Screens.

FORCE
VALVES

Press  to scroll through FORCE VALVES Screens.

Main MHG REHEAT Screens

Refer to the following map when navigating through the Main Screens. From the MHG REHEAT Screen, press **<ENTER>** to scroll through the screens.

MHG
REHEAT



S/A MODE,
SA MODE LOCKED
or COMM MODE

In Stand-Alone Mode, the screen will display S/A MODE or S/A MODE LOCKED.

In Communications Mode, the screen will display COMM MODE and the items below will scroll through the screen:

1. Number of good packets being received. This will roll over after 9999. Example: +XXXX
2. Number of checksum errors. This will stop at 9999. Example: C-XXXX
3. Number of packet length errors. This will stop at 9999 until power is cycled. Example: P-XXXX



SOFTWARE
VER 3.06

CURRENT SOFTWARE VERSION



ADDRESS
#

CURRENT BOARD ADDRESS



LCD SCREENS

Status and Alarm Screens

Status Screens

Refer to the following map when navigating through the Status Screens. From the STATUS Screen, press <ENTER> to scroll through the screens.



Status Screens shown below will scroll automatically if LCD display is left on this screen for 20 seconds.



MODE

This screen displays the current mode of operation of the MHGRV-X. The mode options are:

OFF: This mode will display if the unit is not in Dehumidification Mode and there is no call for Modulating Hot Gas Reheat (MHGR).

REHEAT: During Dehumidification, the unit will enter the Reheat Mode and will begin to modulate the MHGR Valve to maintain the Supply Air Temperature Setpoint. The unit will leave the Reheat Mode when the unit leaves the Dehumidification Mode.

FLUSH: This mode will display if the unit is performing a cooling flush cycle or a reheat flush cycle (see Additional Features, [page 11](#)).

AUX: If Aux operation has been enabled, a 0-10 VDC signal can be used to proportionally modulate the MHGR Valve between 0 – 100 %.

FORCE!: The unit is in the Force Mode.

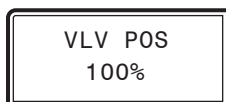

VALVE POSITION

0 to 100 percent



SUPPLY AIR TEMPERATURE

40°F to 150°F or 5°C to 65°C.

If no sensor is detected, screen will display "NO SENSR"

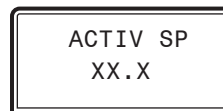

ACTIVE SUPPLY AIR SETPOINT

Calculated from SAT setpoint and reset signal. Displays INACTIVE when in OFF Mode or not needing to be calculated.

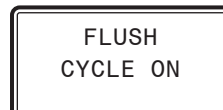
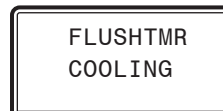

FLUSH TIMER AND FLUSH STATUS

Flush Timer screen will display if the unit is in Cooling Flush Mode, Reheat Flush Mode, or Disabled. It will then display the time remaining in minutes until the Flush Cycle begins. If the unit is in the Flush Cycle, it will display FLUSH CYCLE ON.

Alarm Screens

Refer to the following map when viewing Alarm Screens. These screens will display automatically when alarms are present. For more information, see [pages 16 and 17](#).

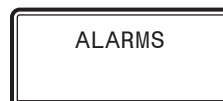

The alarms are as follows:

NO ALARMS: This will be shown if there are no current alarms.

SAT FAIL ERROR: The Supply Air Temperature sensor has been disconnected for more than 60 seconds. This alarm will be disabled when the sensor is reconnected.

COMM T/O ERROR: Communications have been lost with the AAON unit controller. This alarm will disable when communications resume.

Setpoint and Force Valves Screens

Setpoint Screens

Refer to the following map when navigating through the Setpoint Screens. From the SETPOINT Screen, press **<ENTER>** to scroll through the screens and change setpoints. Use the **<UP>** and **<DOWN>** arrow keys to change your selections. Then press **<ENTER>** to save the new setpoint.

WARNING: When the MHGRV-X is operating in Communications Mode (connected to the AAON unit controller), these Setpoint Screens will not appear on the LCD display because they are controlled by the AAON unit controller. To access these Setpoints, temporarily disconnect the MHGRV-X from the AAON unit controller.

SETPOINT



SAT SP
40 - 150°F

REHEAT SUPPLY AIR TEMPERATURE SETPOINT

This is the target temperature while reheat is enabled. If you are using the reset signal, this is the setpoint it will calculate to at zero volts. Will display only in Stand-Alone Mode. The SAT Setpoint is set by the LCD Display in Stand-Alone Mode and is set by the AAON unit controller in communicating mode.

Minimum	Default	Maximum
40°F 5°C	70°F 21°C	150°F 65°C



RESET SP
40 - 150 °F

RESET REHEAT SUPPLY AIR SETPOINT

This is maximum temperature at which the Supply Air Temperature will reset to. Will display only in Stand-Alone Mode. The Reset SAT Setpoint is set by the LCD Display in Stand-Alone Mode and is set by the AAON unit controller in communicating mode.

Minimum	Default	Maximum
40°F 5°C	70°F 21°C	150°F 65°C

Force Valves Screens

Refer to the following map when navigating through the Force Screens. From the FORCE VALVES Screen, press **<ENTER>**. At the FORCE MODE ON/OFF screen, press the **<UP>** arrow key to turn the FORCE MODE on and press the **<DOWN>** arrow key to turn the FORCE MODE off.

NOTE: When you turn the Force Mode back off or after one hour has elapsed, the valves will reinitialize to zero.

FORCE
VALVES



FORCE
MODE ON/OFF

Press the **<UP>** button to turn the Force Mode on. Press the **<DOWN>** button to turn the Force Mode off.



FRC VALV
X%

FORCE VALVE PERCENTAGE

This screen only appears when Force Mode is on.

Press the **<UP>** button to increase the percentage. Press the **<DOWN>** button to decrease the percentage.



FRC EXP
X%

FORCE EXPANSION VALVE PERCENTAGE

This screen only appears when Force Mode is on and Expansion Valves are Enabled.

Press the **<UP>** button to increase the percentage. Press the **<DOWN>** button to decrease the percentage.



FORCE
TIMEOUT

FORCE MODE TIME OUT

This screen will appear when the Force Mode times out after one hour.

TROUBLESHOOTING

LED Diagnostics

General

The MHGRV-X is equipped with LEDs that can be used to verify operation and perform troubleshooting. There are LEDs for communication, operation modes, and diagnostic codes. The module has 14 LEDs—12 used for operation and status, and two used for alarms.

See **Figure 5, page 17** for the LED locations. The LEDs associated with these inputs and outputs allow you to see what is active without using a voltmeter. The LEDs and their uses are as follows:

Operation LEDs

POWER - This green LED will light up to indicate that 24 VAC power has been applied to the controller.

STATUS - This green LED will light up and blink the board address at startup. It will then blink according to what mode the controller is in. See **Table 4, this page**. Only the highest priority failure code will be shown. You must correct the highest priority alarm before other problems will be indicated.

No. of Blinks	STATUS LED
1	Off Mode
2	Reheat Mode
3	Flush Mode
4	Force Mode
5	SAT Sensor Failure Mode

Table 4: STATUS LED Blink Codes

Diagnostic LEDs

ALARM - This red LED will light up to indicate an alarm. The type of alarm will display on the LCD display. The ALARM LED also blinks when the expansion valve is initializing at startup.

No. of Blinks	ALARM LED
1	Supply Air Temperature Sensor Failure
2	Communications Time Out Error

Table 5: ALARM LED Blink Codes

Communication LED

COMM - This yellow LED will light up and blink when communications are detected.

Relay LEDs

FAN - This green LED will light up to indicate that the relay for the “FAN” output is energized and its Normally Open Contact is closed.

COMP - This green LED will light up to indicate that the relay for the “COMP” output is energized and its Normally Open Contact is closed.

VALVE - This green LED will light up to indicate that the relay for the “VALVE” output is energized and its Normally Open Contact is closed.

AUX - This green LED will light up to indicate that the relay for the “AUX” output is energized and its Normally Open Contact is closed.

Binary Input LEDs

REHEAT ENABLE - This green LED will light up when the Reheat is enabled.

HEAT OVERRIDE - This green LED will light up when Heat Override is enabled.

COOL OVERRIDE - This green LED will light up when Cool Override is enabled.

Analog Output LEDs

CONDENSER VALVE DRIVE - This LED blinks any time the condenser valve is opening and reheat valve is closing.

REHEAT VALVE DRIVE - This LED blinks any time the reheat valve is opening and the condenser valve is closing.

LED Troubleshooting

“POWER” LED - When the MHGRV-X is powered up, the POWER LED should light up and stay on continuously. If it does not light up, check to be sure that the power wiring is connected to the board, the connections are tight, and the transformer is powered. If after making all these checks, the POWER LED does not light up, the board is probably defective.

“STAT” LED - As previously described, when the board is first powered up, the STAT LED will do the following:

- On for 10 seconds
- Blinks 30 times
- Blinks three times rapidly (after STEP LED is on for 45 seconds)
- Status code is repeatedly blinked every 10 seconds to indicate controller status

Supply Air Temperature Failure

- Verify that the Supply Air Temperature Sensor is connected to the SAT and GND on the MHGRV-X or MODGAS Controller (Stand-Alone Mode or when using a CAV/VAV or MUA controller) or to AI2 and GND on the AAON unit controller (communicating mode).
- Remove SAT and GND wiring from MHGRV-X and ohm sensor out (this may indicate open or failed wiring). Refer to chart in back of this guide for readings.
- Verify the SAT OPTIONS jumper settings on the MHGRV-X for the Supply Air Temperature Sensor.

Communications Loss

- Check COMM LED on MHGRV-X.
- Verify 24 VAC power to all interconnected AAON unit controllers.
- Verify E-BUS connection between the MHGRV-X and associated AAON unit controllers.
- In communication mode (connected to an AAON unit controller with modular cable), confirm that controller's MHGRV-X status screen displays MHGRV-X's Position % and that Main MHG Reheat screens show COMM MODE.

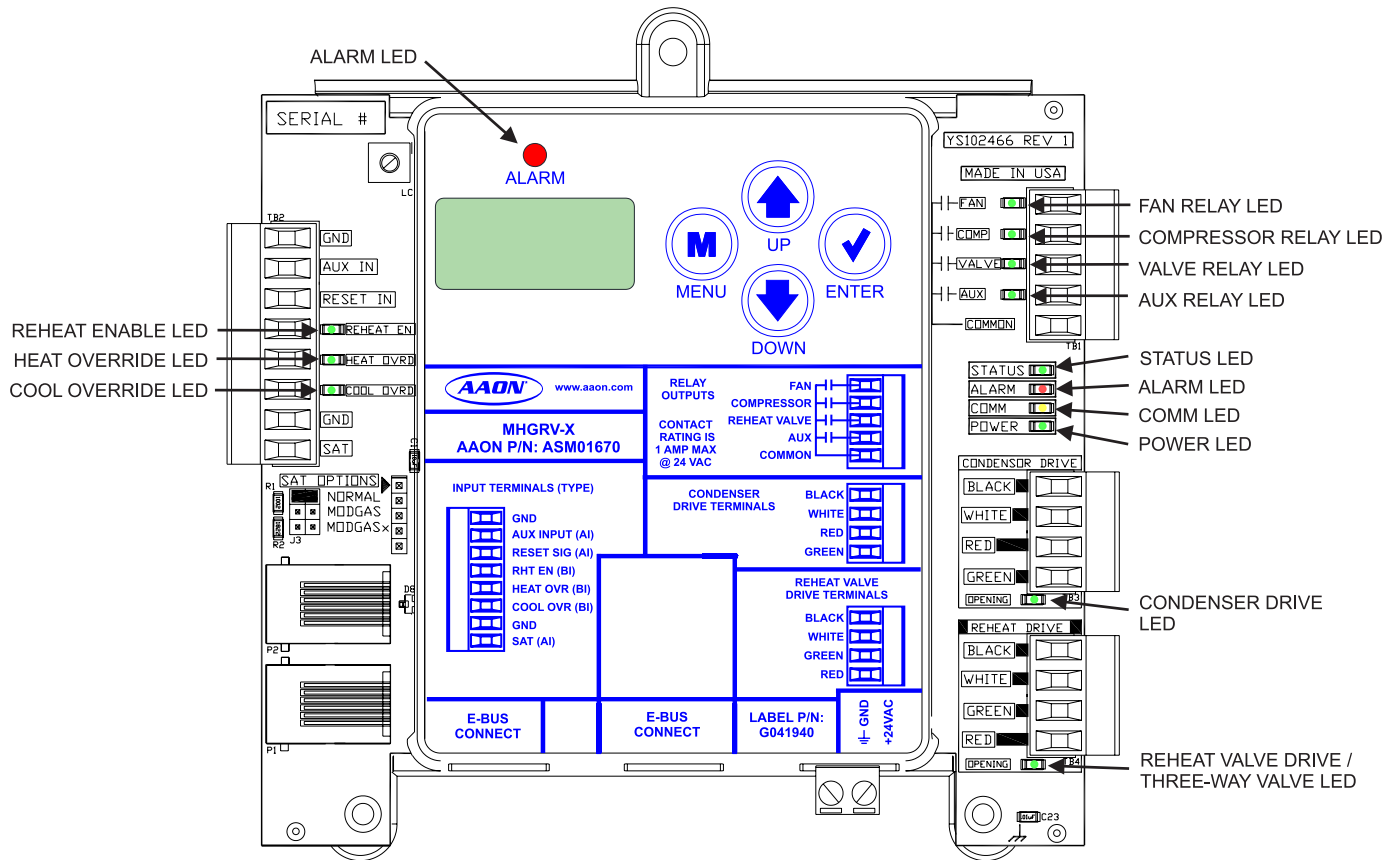

Figure 5: MHGRV-X LED Locations and Descriptions

TROUBLESHOOTING

Other Checks

Supply Air Temperature Sensor

If you suspect the Supply Air Temperature Sensor is not reading correctly, make sure the wiring terminal connections are tight and that any wiring splices are properly connected. You can check the operation of the Supply Air Temperature Sensor by measuring the resistance or voltage using a digital multimeter.

Measuring Voltage

Set the meter to DC Volts. Place the positive probe on the AIN terminal and the negative probe on the GND terminal. Read the DC Volts and find that voltage in **Table 6, this page** and **Table 7, page 19**. Read the temperature corresponding with that voltage and determine if this is close to the actual temperature the sensor is exposed to. If the temperature from the chart is different by more than a few degrees, you probably have a defective or damaged sensor.

Thermistor Sensor Testing Instructions

1. Use the resistance column to check the thermistor sensor while disconnected from the controllers (not powered).
2. Use the voltage column to check sensors while connected to powered controllers. Read voltage with meter set on DC volts. Place the “-” (minus) lead on GND terminal and the “+” (plus) lead on the sensor input terminal being investigated.

Measuring Resistance

To read the resistance, set the meter to Ohms. Unplug the sensor connector from the board and measure the resistance across the disconnected wires. This resistance should match the corresponding temperature from **Table 6, this page** and **Table 7, page 19**.

TEMPERATURE TO RESISTANCE/VOLTAGE CHART

Temp (°F)	Temp (°C)	Resistance (Ohms)	Voltage @ Input (VDC)	Temp (°F)	Temp (°C)	Resistance (Ohms)	Voltage @ Input (VDC)
-10	-23.3	93333	2.98	72	22.2	11136	1.74
-5	-20.6	80531	2.94	73	22.8	10878	1.72
0	-17.8	69822	2.89	74	23.3	10625	1.70
5	-15	60552	2.83	75	23.9	10398	1.68
10	-12.2	52500	2.77	76	24.4	10158	1.66
15	-9.4	45902	2.71	78	25.6	9711	1.63
20	-6.6	40147	2.64	80	26.7	9302	1.59
25	-3.9	35165	2.57	82	27.8	8893	1.55
30	-1.1	30805	2.49	84	28.9	8514	1.52
35	1.7	27140	2.41	86	30	8153	1.48
40	4.4	23874	2.33	88	31.1	7805	1.45
45	7.2	21094	2.24	90	32.2	7472	1.41
50	10	18655	2.15	95	35	6716	1.33
52	11.1	17799	2.11	100	37.8	6047	1.24
54	12.2	16956	2.08	105	40.6	5453	1.16
56	13.3	16164	2.04	110	43.3	4923	1.09
58	14.4	15385	2.00	115	46.1	4449	1.02
60	15.6	14681	1.96	120	48.9	4030	.95
62	16.7	14014	1.93	125	51.7	3656	.88
64	17.8	13382	1.89	130	54.4	3317	.82
66	18.9	12758	1.85	135	57.2	3015	.76
68	20	12191	1.81	140	60	2743	.71
69	20.6	11906	1.79	145	62.7	2502	.66
70	21.1	11652	1.78	150	65.6	2288	.61
71	21.7	11379	1.76				

Note: If the voltage is above 3.3 VDC the sensor or wiring is “open.” If the voltage is less than 0.05 VDC, the sensor or wiring is shorted.

Table 6: 0-3V Temperature Sensor - Voltage and Resistance for Type III Sensors

Thermistor Sensor Testing Instructions

1. Use the resistance column to check the thermistor sensor while disconnected from the controllers (not powered).
2. Use the voltage column to check sensors while connected to powered controllers. Read voltage with meter set on DC volts. Place the “-” (minus) lead on GND terminal and the “+” (plus) lead on the sensor input terminal being investigated.

Measuring Resistance

To read the resistance, set the meter to Ohms. Unplug the sensor connector from the board and measure the resistance across the disconnected wires. This resistance should match the corresponding temperature from **Table 6, this page** and **Table 7, page 19**.

TEMPERATURE TO RESISTANCE/VOLTAGE CHART

Temp (°F)	Temp (°C)	Resistance (Ohms)	Voltage @ Input (VDC)	Temp (°F)	Temp (°C)	Resistance (Ohms)	Voltage @ Input (VDC)
-10	-23.3	93333	4.620	72	22.2	11136	2.695
-5	-20.6	80531	4.550	73	22.8	10878	2.665
0	-17.8	69822	4.474	74	23.3	10625	2.635
5	-15	60552	4.390	75	23.9	10398	2.607
10	-12.2	52500	4.297	76	24.4	10158	2.577
15	-9.4	45902	4.200	78	25.6	9711	2.520
20	-6.6	40147	4.095	80	26.7	9302	2.465
25	-3.9	35165	3.982	82	27.8	8893	2.407
30	-1.1	30805	3.862	84	28.9	8514	2.352
35	1.7	27140	3.737	86	30	8153	2.297
40	4.4	23874	3.605	88	31.1	7805	2.242
45	7.2	21094	3.470	90	32.2	7472	2.187
50	10	18655	3.330	95	35	6716	2.055
52	11.1	17799	3.275	100	37.8	6047	1.927
54	12.2	16956	3.217	105	40.6	5453	1.805
56	13.3	16164	3.160	110	43.3	4923	1.687
58	14.4	15385	3.100	115	46.1	4449	1.575
60	15.6	14681	3.042	120	48.9	4030	1.469
62	16.7	14014	2.985	125	51.7	3656	1.369
64	17.8	13382	2.927	130	54.4	3317	1.274
66	18.9	12758	2.867	135	57.2	3015	1.185
68	20	12191	2.810	140	60	2743	1.101
69	20.6	11906	2.780	145	62.7	2502	1.024
70	21.1	11652	2.752	150	65.6	2288	0.952
71	21.7	11379	2.722				

Note: If the voltage is above 5.08 VDC the sensor or wiring is “open.” If the voltage is less than 0.05 VDC, the sensor or wiring is shorted.

Table 7: 0-5V Temperature Sensor - Voltage and Resistance for Type III Sensors

APPENDIX A: SAT SENSOR

Supply Air Temperature Sensor Installation

Mounting the Supply Air Temperature Sensor

The Supply Air Temperature Sensor should be located in the ductwork downstream of the unit supply air connection. Locate the sensor in the center of the widest part of the duct. Use the supplied template and a 5/16 inch drill to make a hole for the sensor. Install the gasket over the probe and mount securely to the duct using the supplied sheet metal screws. Be sure the gasket is compressed to provide an air tight seal. To help prevent thermal gradients from affecting the sensor, apply insulation on the outside of the duct, over the sensor.

WARNING: Make sure your Supply Air Temperature Sensor is mounted and wired according to these instructions prior to testing the unit or else the modulating valve will not control properly and may damage your equipment.

Stand-Alone Mode

In Stand-Alone Mode, the SAT Sensor is connected to the MHGRV-X. If, in Stand-Alone Mode, the MHGRV-X is used in conjunction with a Stand-Alone MODGAS-X, the SAT sensor is shared between the two controllers and always attaches to the MODGAS-X.

See **Table 9, page 21** for SAT Options Jumper Settings and see **Figure 3, page 8** for wiring.

Communication Mode

When communicating with AAON unit controllers, the SAT Sensor will be connected to the AAON unit controller. The exception would be in retrofit applications with older controllers. See **Table 10, page 21** for SAT Options Jumper Settings and see **Figure 2, page 7** for wiring. See **Table 8, page 21** and **Appendix B, page 22** for details about retrofit applications.

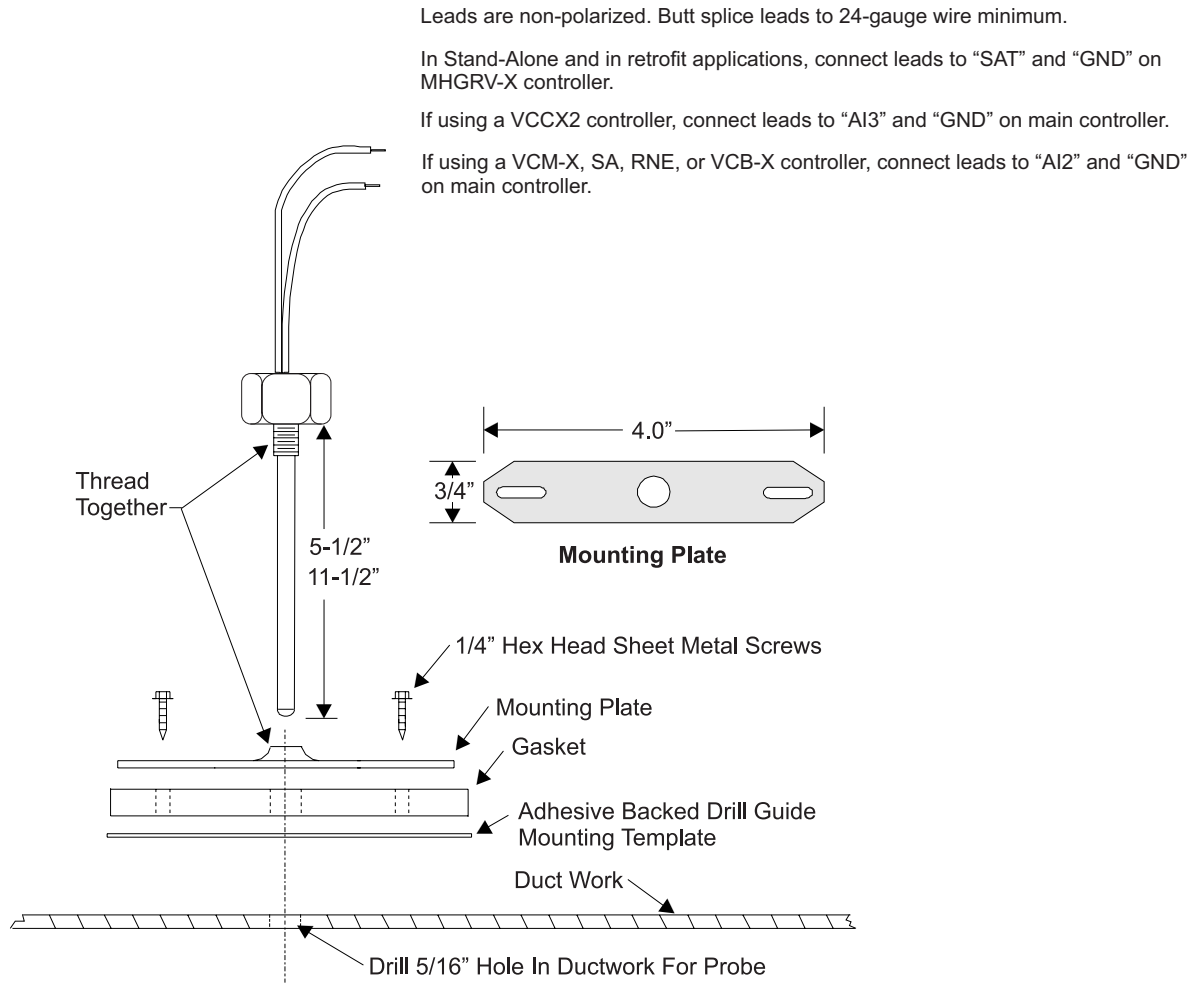

Figure 6: Supply Air Temperature Sensor Installation

SAT Sensor Wiring Guide and Jumper Settings

SAT Wiring Conditions

SAT OPTIONS Jumper Settings

Refer to **Tables 9 and 10**, this page to determine the SAT OPTIONS Jumper Settings. See **Figures 2 and 3** on pages 7 and 8 for jumper locations.

	MODGAS-X ONLY	MHGRV-X ONLY	MODGAS-X AND MHGRV-X
Stand-Alone	Install Supply Air Sensor in MODGAS-X.	Install Supply Air Sensor in MHGRV-X. Set "SAT Options" Jumpers to "Normal".	Install Sensor in MODGAS-X and daisy-chain it to the MHGRV-X. Set "SAT Options" Jumpers to "MODGAS X". If connected to a MODGAS II Retrofit, Set "SAT Options" Jumpers to "MODGAS".
VCCX2 VCB-X	Install Supply Air Sensor in VCCX2 or VCB-X. Connect to VCCX2 or VCB-X using E-BUS cable.	Install Supply Air Sensor in VCCX2 or VCB-X. Connect to VCCX2 or VCB-X using E-BUS cable.	Install Supply Air Sensor in VCCX2 or VCB-X. Connect to VCCX2 or VCB-X using E-BUS cable.
VCM-X, SA, RNE	Install Supply Air Sensor in AAON unit controller. Connect to AAON unit controller using I ² C cable.	Install Supply Air Sensor in AAON unit controller. Connect to main controller using I ² C cable.	Install Supply Air Sensor in AAON unit controller. Connect to AAON unit controller using I ² C cable.
VCM, VAV/CAV, MUA, MUA II, MUA IID	Install Supply Air Sensor in MODGAS-X. Connect to AAON unit controller using I ² C cable.	Install Supply Air Sensor in MHGRV-X. Connect to AAON unit controller using I ² C cable.	Install Supply Air Sensor in MODGAS-X. Connect to AAON unit controller using I ² C cable.

Table 8: SAT Wiring Conditions

STAND-ALONE MODE SAT OPTIONS JUMPER SETTINGS*	
CONDITION	SETTING
MHGRV-X Only	Normal
MHGRV-X with MODGAS-X**	MODGAS-X
MHGRV-X with MODGAS II***	MODGAS
* For SAT Sensor testing, use Table 6 for Normal and MODGAS-X jumper setting and use Table 7 for MODGAS jumper setting.	
** In this situation, also set MODGAS-X SAT Option to Jumper Setting 1. See the <i>MODGAS-X Technical Guide</i> for more information.	
*** The MODGAS II must have PU1 resistor installed.	

Table 9: Stand-Alone Mode SAT OPTIONS Jumper Settings

COMMUNICATION MODE SAT OPTIONS JUMPER SETTINGS*	
CONDITION	SETTING
VCM / VCM-X / SA/ RNE *	Normal
MUA, VAV/CAV**	Normal
VCCX2, VCB-X*	Normal
* For SAT Sensor testing, use Table 6 for Normal jumper setting. SAT should be connected to the AAON unit controller.	
** For SAT Sensor testing, use Table 6 for Normal jumper setting. SAT should be connected to the MHGRV-X.	

Table 10: Communication Mode SAT OPTIONS Jumper Settings

MHGRV-X Replacement of MHGRV II

Replacing the MHGRV II with the MHGRV-X

The drop-in replacement involves a few easy steps. Refer to **Figure 7, this page**.

Stand-Alone Mode Operation

- Step 1:** Disconnect power from the MHGRV II.
- Step 2:** Disconnect the Supply Air Temperature Sensor from the MHGRV II and wire it to the MHGRV-X. If the Supply Air Temperature Sensor is being shared with a Stand-Alone MODGAS Controller, maintain the same wiring with the MODGAS Controller.
- Step 3:** Separate the HGR Valve wires and the Condenser Valve wires onto the appropriate Reheat Drive and Condenser Drive terminal blocks per **Figure 3, page 8**. Wire all other inputs and outputs per **Figure 3**.
- Step 4:** Set the SAT Options Jumper per **Table 9, page 21**.
- Step 5:** Connect power to the MHGRV-X.

Communications Mode Operation

- Step 1:** Disconnect power from the MHGRV-II.
- Step 2:** The Supply Air Temperature Sensor needs to remain installed on whatever controller it is currently on. If it is currently installed on the MHGRV II then reinstall it on the MHGRV-X. If it is currently installed on the main unit controller or on a connected MODGAS, it needs to remain there.
- Step 3:** Set the SAT Options Jumper per **Table 10, page 21**.
- Step 4:** Connect power to the MHGRV-X.

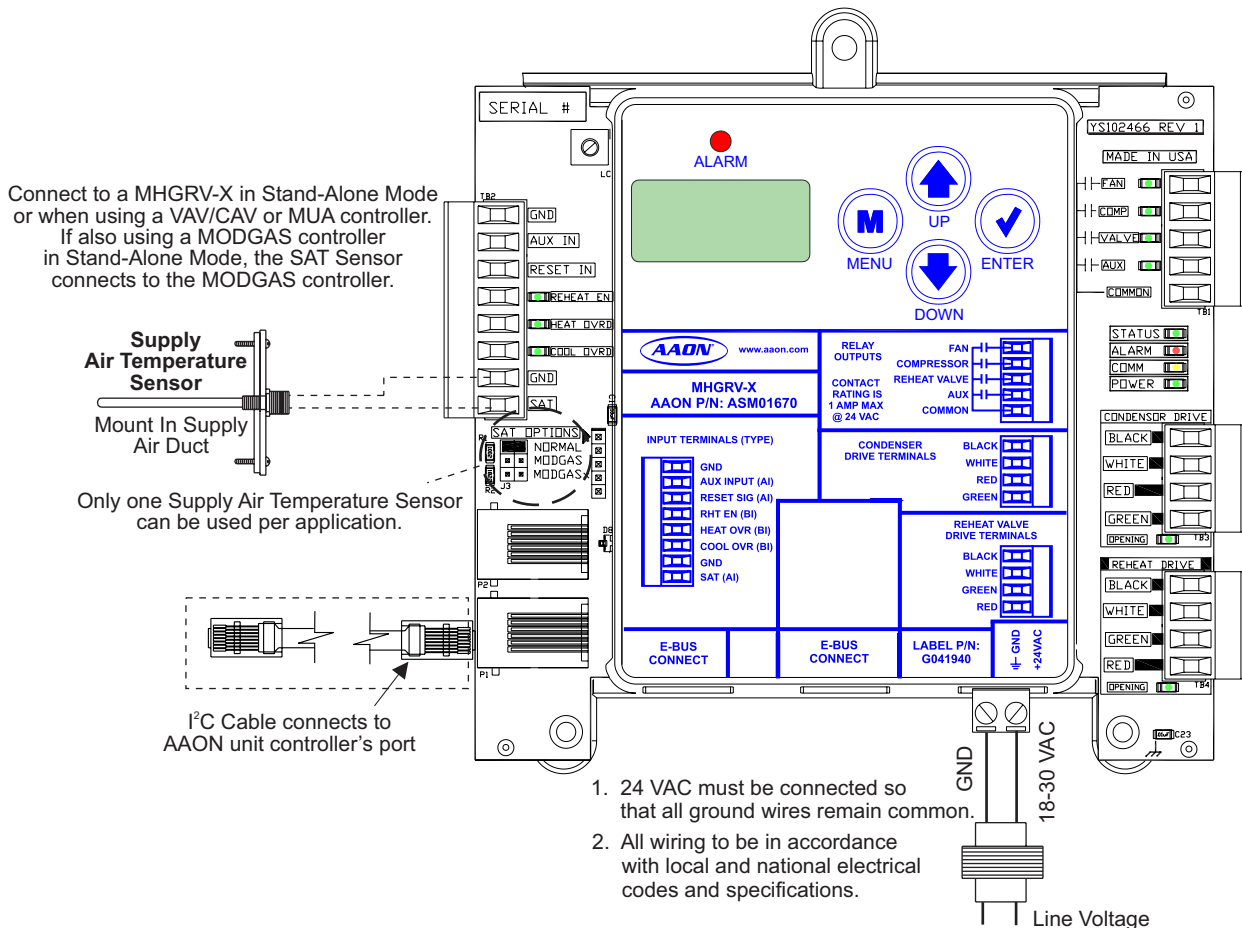

Figure 7: MHGRV-X Replacement Wiring

Overview

The ASM01687 Reheat Expansion Module is designed to control one set of reheat valves.

The Reheat Expansion Module connects to the MHGRV-X via an EBC E-BUS communication cable.

Connected together, the Reheat Expansion Modules provide a system that allows the proper control of multiple sets of valves.

See **Figure 8, this page** for dimensions.

Features

The Reheat Expansion Module provides the following:

- Up to seven Reheat Expansion Modules can be used
- Each Reheat Expansion Module controls one set of reheat valves (one Reheat and one Condenser)
- Each Reheat Expansion Module has its own Cooling
- Reheat Flush Timers
- Reheat Expansion Modules conveniently plug into one another

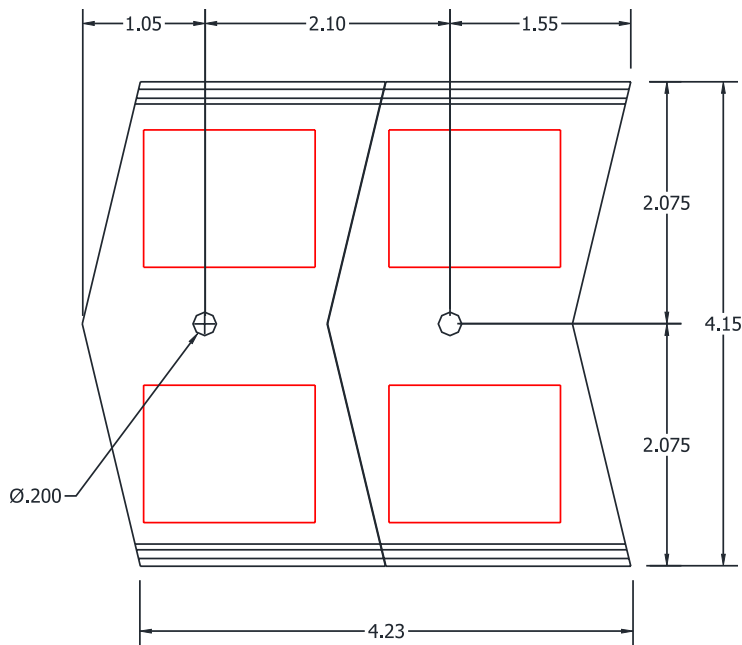

(2) Chevron Cut Snap Tracks

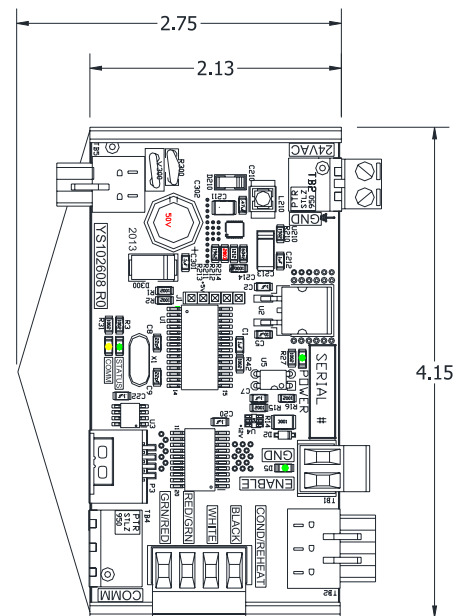

Reheat Expansion Module

NOTE: All dimensions are in inches.

Figure 8: Reheat Expansion Module and Mounting Plate Dimensions

Installation and Wiring

Installation and Mounting

The Reheat Expansion Module is provided with a Chevron cut plastic snap track mounting base. The snap track is designed to be mounted using a ¼" Hex Head Sheet Metal Screw (provided) to a flat surface using the pre-punched mounting hole that is provided in the center of the snap track. The Reheat Expansion Module is then snapped into place on the snap track, providing for easy field mounting and servicing.

The Reheat Expansion Module needs to be installed in an environment which can maintain a temperature range between -22°F and 158°F not to exceed 95% RH levels (non-condensing). It is important to keep the module in a location that is free from extreme high or low temperatures, moisture, dust, and dirt. Be careful not to damage the electronic components.

NOTE: The Reheat Expansion Module contain no user-serviceable parts. Contact qualified technical personnel if your Controller or Module is not operating correctly.

General Wiring Information

For the wiring diagram to use when the MHGRV-X is connected to an AAON unit controller, see **Figure 2, page 7**. For the Stand-Alone wiring diagram, see **Figure 3, page 8**.

For Reheat Expansion Board wiring, see **Figure 9, page 25**.

Please carefully read and apply the following information when wiring the Reheat Expansion Module(s):

1. 18-gauge minimum wire unless otherwise noted.
2. 24 VAC power connection with an appropriate VA rating.
3. Compressor Enable must have 24-gauge minimum wire.
4. All 24 VAC wiring must be connected so that all ground wires remain common. Failure to follow this procedure can result in damage to the module and connected devices.
5. All wiring is to be in accordance with local and national electrical codes and specifications.
6. Check all wiring leads at the terminal block for tightness. Be sure that wire strands do not stick out and touch adjacent terminals. Confirm that all transducers required for your system are mounted in the appropriate location and wired into the correct terminals.

Reheat Expansion Module(s) Wiring

Reheat Expansion Modules snap into each other at the power and Comm connectors. Up to seven Reheat Expansion Modules can be used.

Apply power to the first Reheat Expansion Module in a series. The last Reheat Expansion Module in a series connects to the MHGRV-X using an EBC E-BUS cable.

See **Figure 9**, this page for details.

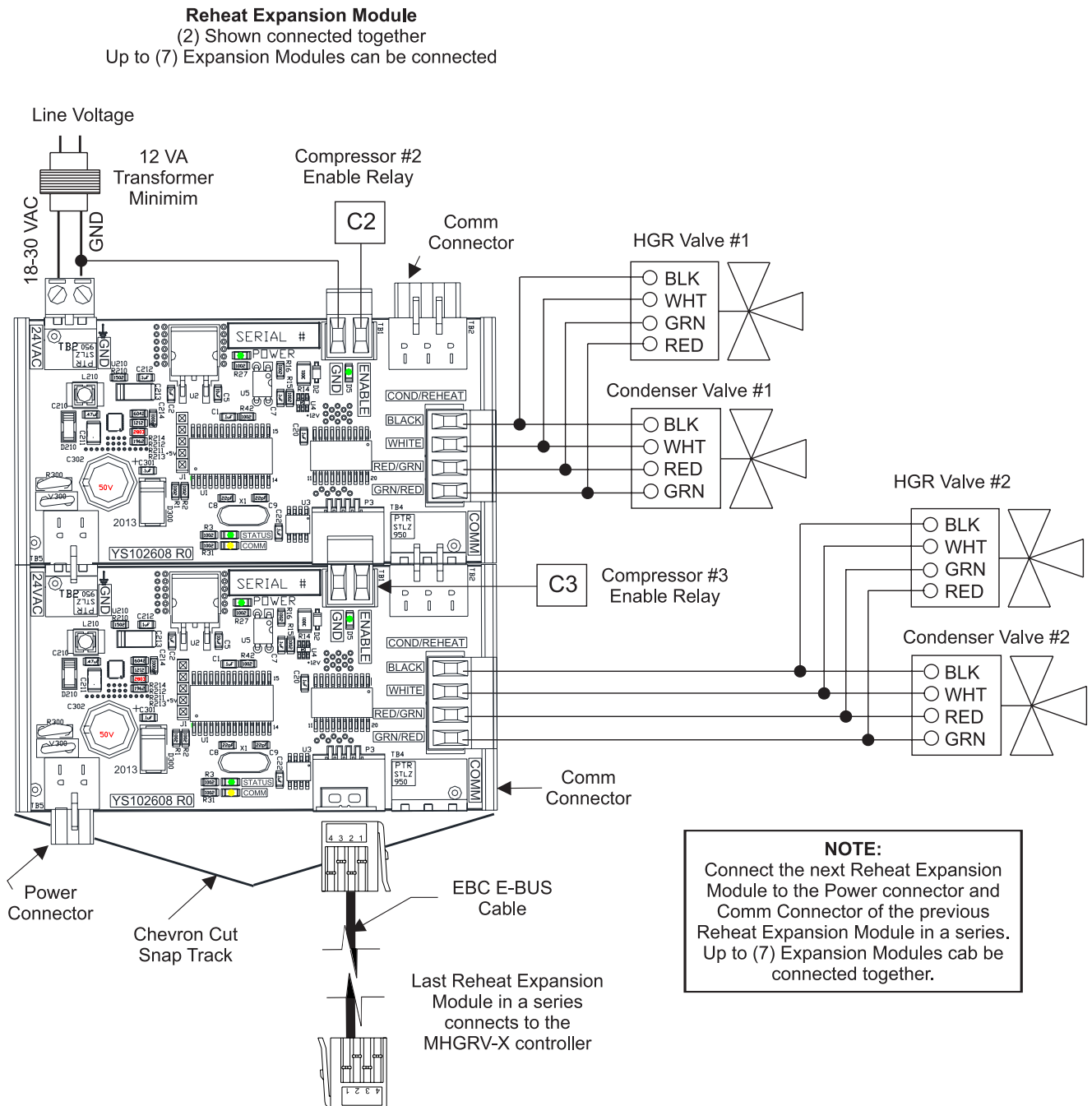

Figure 9: Reheat Expansion Module(s) Wiring

Operation Modes

Initialization

The Reheat Expansion Module uses on-board LEDs to indicate various diagnostic conditions during power-up and operation. See the LED Operation section on **page 27** for more information.

Modulating Hot Gas Valves

Each Reheat Expansion Module utilizes two modulating valves to control the flow of Hot Gas through the Hot Gas Reheat Coil. One of these valves is the Condenser Hot Gas Valve and the other is the Hot Gas Reheat Valve. The valves are wired to the Reheat Expansion Module's Modulating Hot Gas Valve Output terminals. These valves work in concert with each other to create a "three-way valve" configuration. As one closes, the other opens, etc. All modes of operation that follow referring to the Hot Gas Reheat Valve are actually a combination of these two valves working together to achieve the specified sequence of operation.

Mode of Operation

The Reheat Expansion Module(s) can be used in MHGRV-X Stand-Alone operation and when the MHGRV-X is communicating to an AAON unit controller.

Stand-Alone Operation

See **page 10** for MHGRV-X Stand-Alone operation. Once the Reheat Expansion Module's Binary Input Compressor input is enabled, the valve positions follow the MHGRV-X.

Operation in Communicating Mode

In this mode, the MHGRV-X behaves as an expansion board for an AAON unit controller. See **page 10** for detailed operation. Once the Reheat Expansion Module's Binary Input Compressor input is enabled, the valve positions follow the MHGRV-X.

Additional Features

Reheat Coil Flush

To assure positive oil return to the compressor, the Hot Gas Reheat Coil will be flushed of liquid refrigerant by moving the Modulating Gas Reheat Valve to its maximum position for a short interval.

Cooling Flush

If the unit is in cooling mode, a flush will occur when the unit's flush cooling interval timer has elapsed. The time is accumulated whenever it is in cooling mode and resets after each flush cycle. The flush cooling interval timer is a setpoint that is configurable using the keypad and display (0 to 120 minutes in 10 minute increments). If enabled, each Reheat Expansion Module follows the same sequence as the MHGRV-X, using the same cooling flush interval timer of the MHGRV-X. The expansion boards do not flush at the same time.

Reheat Mode Flush

If the unit is in dehumidification mode and the valve is below 70% for the flush reheat interval timer value, a flush will occur. If the valve goes above 70%, the timer is reset. The flush reheat interval timer is a setpoint that is configurable using the keypad and display (0 to 120 minutes in 10 minute increments). If enabled, each Reheat Expansion Module follows the same sequence as the MHGRV-X, using the same flush reheat interval timer of the MHGRV-X. The expansion boards do not flush at the same time.

Optional Flush Mode Configurations

A configuration option is available that will provide a 30 second flush cycle whenever the unit enters the cooling, dehumidification, and heat pump modes. If using Reheat Expansion Module(s) in conjunction with the MHGRV-X, a configuration option is available to force all the valves to flush synchronously instead of independently.

Contact AAON Controls Support for assistance in making these configuration changes.

LED Diagnostics

The Reheat Expansion Module is equipped with four LEDs that can be used to verify operation and perform troubleshooting.

See **Figure 10, this page** for the LED locations. The LEDs associated with these inputs and outputs allow you to see what is active without using a voltmeter. The LEDs and their uses are as follows:

Operation LEDs

- **POWER:** This green LED will light up to indicate that 24 VAC power has been applied to the Expansion Module.
- **STATUS:** This green LED will light up and blink every 10 seconds according to valve position. One blink per 10%. Example: valve position is 67%. STATUS LED will blink six times every 10 second cycle. The STATUS LED will stay on solid during the two-minute flush cycle. See **Table 11, this page**.

No. of Blinks	STATUS LED
1-10	Per 10% Valve Position
Solid	During 2 Minute Flush Cycle

Table 11: Reheat Expansion Module ALARM LED Blink Codes

Communication LED

- **COMM:** This amber LED will light up and blink once for every good packet received. Packets should be sent once every second, so the COMM LED should blink the same, once every second. The COMM LED should blink simultaneously on all modules.

Binary Input LED

- **COMPRESSOR ENABLE:** This green LED will light up when the Reheat is enabled.

LED Troubleshooting

- **“POWER” LED:** When the Reheat Expansion Module is powered up, the POWER LED should light up and stay on continuously. If it does not light up, check to be sure that the power wiring is connected to the board, the connections are tight, and the transformer is powered. If after making all these checks, the POWER LED does not light up, the board is probably defective.
- **“STAT” LED:** When the board is first powered up, the STAT LED will do the following:
 - On for 10 seconds
 - Blinks 30 times
 - Status code repeatedly blinks the indicated valve position every ten seconds

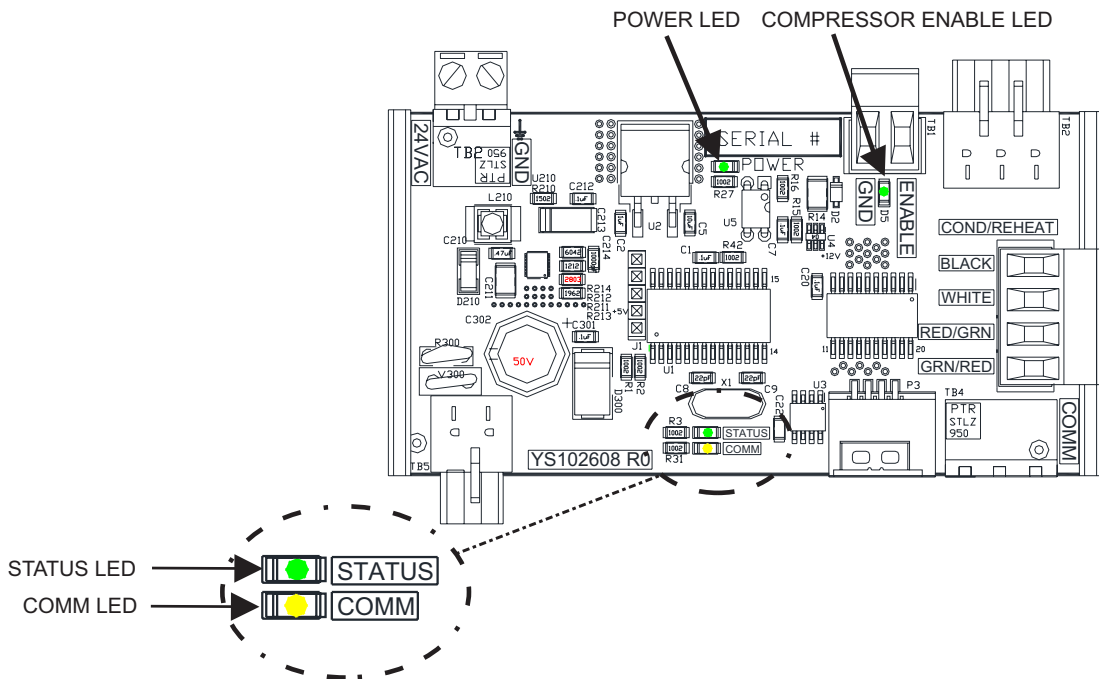

Figure 10: Reheat Expansion LED Locations and Descriptions

Troubleshooting

Q and A

The following are common questions and their answers:

Q: Is there power to the expansion module?

A: The POWER LED should be lit at all times. If not, check the 24 VAC input voltage. If the input voltage is confirmed and the POWER LED is not lit, the board is physically damaged.

Q: Is the expansion module communicating?

A: You should always see the COMM LED(s) blinking simultaneously on all modules. The communication chain is physically connected from board to board; however, the communications circuit is a parallel connection so it is possible one module could be inoperable while others down the chain are operating.

A: If you see the COMM LED on solid, then the module has not detected communications for over 60 seconds.

Q: Is the valve position correct?

A: The STATUS LED will blink the valve position every 10 seconds if the valve is not closed. It will blink the position divided by 10. So, for example, if the position is 68%, the STATUS LED will blink six times.

A: The valve position displayed on the MHGRV-X Status Screen should match the expansion module's valve position. The expansion module must have the enable signal activated for the valve position to mirror the MHGRV-X.

Q: The STATUS LED is on solid. What does this mean?

A: The expansion module is performing its own flush cycle. Each expansion module tracks its own flush cycles. The flush time setpoints are always the same as the MHGRV-X setpoints.

Q: I have no Communications. Can my valve still drive?

A: If communication is lost, the valve will drive closed.

A: If the expansion board is configured (from MHGRV-X) for independent flush cycles: If the cooling enable binary input is activated, the cooling flush timer will run and when the cooling flush time is met, the valve will perform a flush cycle.

A: If the expansion board is configured (from MHGRV-X) for synchronous flush cycles: No flush cycles will occur.

Q: How can I test if the expansion module will drive the valve?

A: From the MHGRV-X, you can go to the Force Menu and manually drive the expansion module valves open and closed.

Q: Are my valves wired correctly?

- A:** Both valves per circuit should be wired to the same terminal block.
- A:** The Condenser Valve should be wired (from top to bottom) BLACK, WHITE, RED, GREEN.
- A:** The Reheat Valve should be wired (from top to bottom) BLACK, WHITE, GREEN, RED.

Q: How do I confirm the expansion module is operating in Reheat (Dehumidification) mode?

- A:** Make sure the enable signal is activated by confirming that the ENABLE LED is on.
- A:** Make sure the COMM LED is blinking.
- A:** Compare the Valve Position displayed on the MHGRV-X screen with the number of STATUS LED blinks.
- A:** If all three things above are true, then the valve is operating correctly in Reheat mode.

Q: Are the communications wired and configured correctly?

A: For the MHGRV-X operating as Stand-Alone, the following should be true:

1. The MHGRV-X is connected to the Reheat Expansion Module with an E-BUS cable and the connections are secure.
2. The MHGRV-X must be configured as S/A LOCKED in the MHGRV-X Configuration Screens. To confirm this, press the ENTER key once from the main screen. It should display S/A MODE LOCKED.
3. The MHGRV-X must be configured for EXP VLVS ENABLED in the MHGRV-X Configuration Screens. If this is true, the COMM LED on the MHGRV-X will blink once every second.

A: For the MHGRV-X operating with a VCCX2/VCB-X, the following should be true:

1. The VCCX2 or VCB-X, MHGRV-X, and Reheat Expansion Module are connected to each other with an E-BUS cable and the connections are secure.
2. The MHGRV-X must be configured as S/A AUTODECT in the MHGRV-X Configuration Screens. To confirm this, press the ENTER key once from the main screen. It should display COMM MODE.
3. The MHGRV-X must be configured for EXP VLVS ENABLED in the MHGRV-X Configuration Screens. If this is true, the COMM LED on the MHGRV-X will blink once every second.

Q: How do I change configurations for the valve expansion modules?

A: Configurations will always match how the MHGRV-X is configured. The configurations are as follows:

1. Valve Size (hidden screen configuration)
2. Cooling Flush Time (setpoint screens when Stand-Alone)
3. Reheat Flush Time (setpoint screens when Stand-Alone)
4. Reheat Flush Reset Position (cannot be changed by user)

MHGRV-X Technical Guide
G086630 · Rev. 01N · 210325

AAON Factory Technical Support: 918-382-6450
techsupport@aaon.com

AAON Controls Support: 866-918-1100
Monday through Friday, 7:00 AM to 5:00 PM
Central Standard Time

Controls Support website:
www.aaon.com/controlstechsupport

NOTE: Before calling Technical Support, please have the model and serial number of the unit available.

PARTS: For replacement parts, please contact your local AAON Representative.



2425 South Yukon Ave • Tulsa, OK • 74107-2728
Ph: (918) 583-2266 • Fax: (918) 583-6094
AAON P/N: **G083360**, Rev. N

Printed in the USA • Copyright March 2021 • All Rights Reserved